



# Delta MVD2000 Series

Medium Voltage Drive



[www.deltaww.com/mvd](http://www.deltaww.com/mvd)





# Contents

<b>Delta Group Introduction</b>	<b>1</b>
<b>Delta MVD 2000 Series</b>	<b>2</b>
<b>Major Application</b>	<b>3</b>
<b>Major Advanced Features &amp; Benefits</b>	<b>4</b>
<b>System Structure</b>	<b>5</b>
<b>Spec. &amp; Parameters</b>	<b>7</b>
<b>Compliance &amp; Standards</b>	<b>9</b>
<b>Product Dimensions</b>	<b>11</b>
<b>Product Selection</b>	<b>12</b>
<b>Installation Diagram</b>	<b>14</b>
<b>Converter Cooling Proposal</b>	<b>15</b>
<b>Reliability &amp; Certificate</b>	<b>16</b>
<b>System Model Names</b>	<b>17</b>
<b>Global Sales &amp; Services</b>	<b>17</b>



## Delta Group

As the world Top 1 switching power supply and energy management solution supplier, Delta Group is also the leading manufacturer in multiple product fields in the world. Delta supplies products including power supply management package solutions, video displays, industrial automation, network communication products, and recycle-energy products.

Delta Group has established business operation branches all over the world, as well as manufacturing plants in Taiwan, China Mainland, Thailand, Mexico, Japan, India, Brazil, and Europe.

As the leading supplier in electrical and electronic industries in the world, Delta Group has defined its operation mission as “Environmental Protection, Energy Saving, and Earth Caring”, and made long-lasting efforts on executing green environmental protections. Delta implemented a green manufacturing process free of lead many years ago, as well as recycling measures and waste retreatment plans.

In the past 40 years, Delta Group insisted on the operation mission of “Environmental protection, Energy Saving, and Caring for the Earth”, pursued continuous innovation, which led to its leading role in many product fields, and being listed in the TOP 50 among Asian Excellent Enterprises sponsored by Forbes.

Delta Group aims to realize environmental protection by establishing and promoting green buildings, and implementing green manufacturing processes, source recycling, and wastes retreatment plans; Delta was elected as the only Chinese enterprise listed in the Global Top 100 Low-Carbon Enterprise sponsored by CNBC. In 2010, Delta was recognized by the Anyong Award of Annual Entrepreneur, Social Responsibility Award and Award of Best Chinese Business Leader by CNBC.

More information refers to the website: [www.deltaww.com](http://www.deltaww.com)



# Delta MVD2000 Series

The MVD2000 is a medium voltage variable speed drive series for speed and torque control based on advanced frequency-conversion multilevel inverter technologies and advanced vector control algorithms. The MVD2000 is a modular and configurable cost-effective solution that provides efficient and reliable operation across many industrial applications. Simple installation requirements, easy operation and maintenance make the MVD2000 the drive of choice across industrial segments that require energy savings or speed control for constant torque loads over the operating speed range.

MVD2000 delivers high performance control accuracy using vector control. The ability to independently control motor flux and speed yields fast dynamic response to load fluctuations and high torque at low speeds, including during motor start-up.

Both encoder and sensor-less vector control approaches are available for selection. The speed sensors can be installed depending on actual application conditions. For cases without the speed sensors, the system can still provide fast dynamic responses and high output torque when the motor is running at low speed.

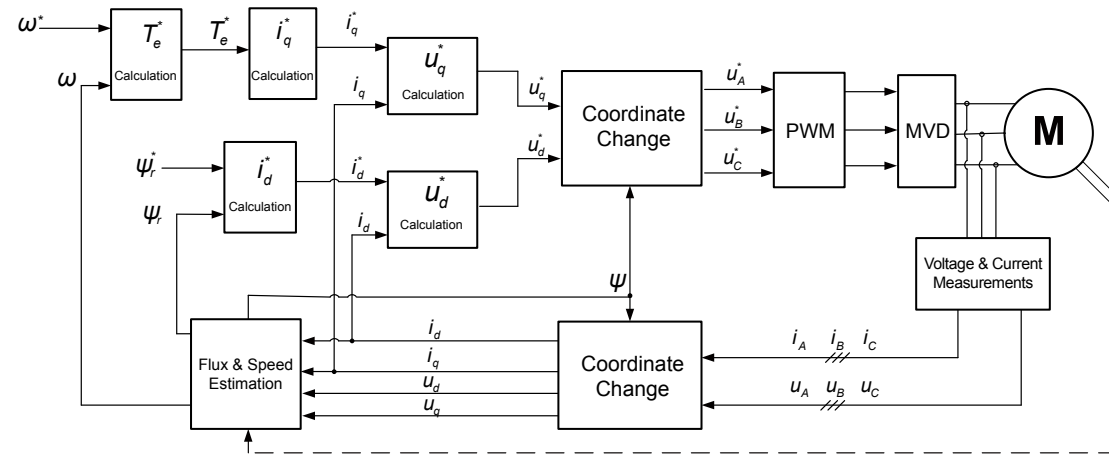

## Applications

The MVD2000 series is applied for speed control of square torque loads such as fans, pumps, and compressors, as well as for mills, crushers, and conveyor belts that require constant torque operation over the entire speed range. Accurate speed and torque controls result in better energy saving, improved process quality, and prolonged equipment lifetime. Various industry segments that require reliable and stable operation can benefit from MVD2000's high performance:

- Power generation: coal mills, blower fans, and water pumps.
- Metallurgy: conveyor belts, positive displacement pumps, fans, and water pumps.
- Mining: crushers, conveyor belts, PD pumps, fans and water pumps.
- Oil & Gas: compressors, PD pumps, centrifugal pumps, fans and water pumps.
- Cement & Materials: crushers, mixers, extruders, rotary kilns, drying furnaces, fans and water pumps.
- Sugar & Ethanol: mills, pumps, and fans.
- Municipal works: water supply pumps, sewage pumps, heat network pumps.





## Advanced Features & Benefits

### Advanced Technologies

- Advanced vector control algorithms with and without speed sensors to enhance motor control performance.
- Advanced auto tuning of motor parameters to improve the stability of the vector control.
- DC current braking injection.
- Power loss ride through, and synchronous transfer for single or several motors.
- Coordination and control of master-slave variable frequency inverters to meet load sharing application requirements.
- Use of phase-shift multi-pulse input transformer to decrease the input grid current harmonics and meet the IEEE 519-1992 requirements.
- Use of cascaded multilevel inverter technologies to deliver nearly sinusoidal output voltage waveforms, meeting motor drive requirements for long-distance cables.

### Enhanced Process & Quality Control

- Capability to produce large output torque at low speeds and during motor startup, increasing speed response and control accuracy within motor torque limits.
- Integrated PID controller for precise control on flow, pressure or other process variable.
- Control operation under temporary input power loss and capability to restart automatically after grid fault and recovery.
- Advanced protection functions such as motor stall and output fault to ground.
- Friendly customer interface for easy system integration with customer's process.

### Control and Monitoring Functions

- Speed command (rpm)
- Operating speed (rpm)
- Input/output power, current, voltage
- Accumulated running time
- MVD status

- System bypass switches and user breaker status
- Programmable analog I/Os
- Alarms and faults
- Event recording

### Lower Cost of Ownership

- System efficiency is higher than 98%, which decreases system operating costs (excluding phase-shift transformer).
- Optimized blower and water pump operations to ensure energy-saving and shorten the investment recovery period.
- Integration of input transformer allows three-cable-in-three-cable-out reduced installation engineering effort.
- Smooth speed control decreases mechanical stress, eliminates pipe-hammer effect and reduces maintenance costs.
- Multilevel output voltage and controlled starting currents reduce motor stress.
- Synchronous transfer switchgear cabinet for soft starter applications for single or multiple motors.

### Protection Functions

- Over-current protection
- Over-load protection
- Transformer high-temperature alarm & over-temperature protection
- MVD over-temperature protection
- Under-voltage & over-voltage protection
- Motor over-load protection (external protection relay connection)
- Cooling fan abnormal alarm
- Cabinet door open protection
- Cabinet pressure alarm
- Output short-circuit protection
- Input/output phase loss protection
- Communication failure protection
- Output grounding protection
- Motor stall alarm/protection
- Motor reverse rotation alarm/protection
- Over-speed and under-speed alarm/protection

## System Structure

### System Diagram

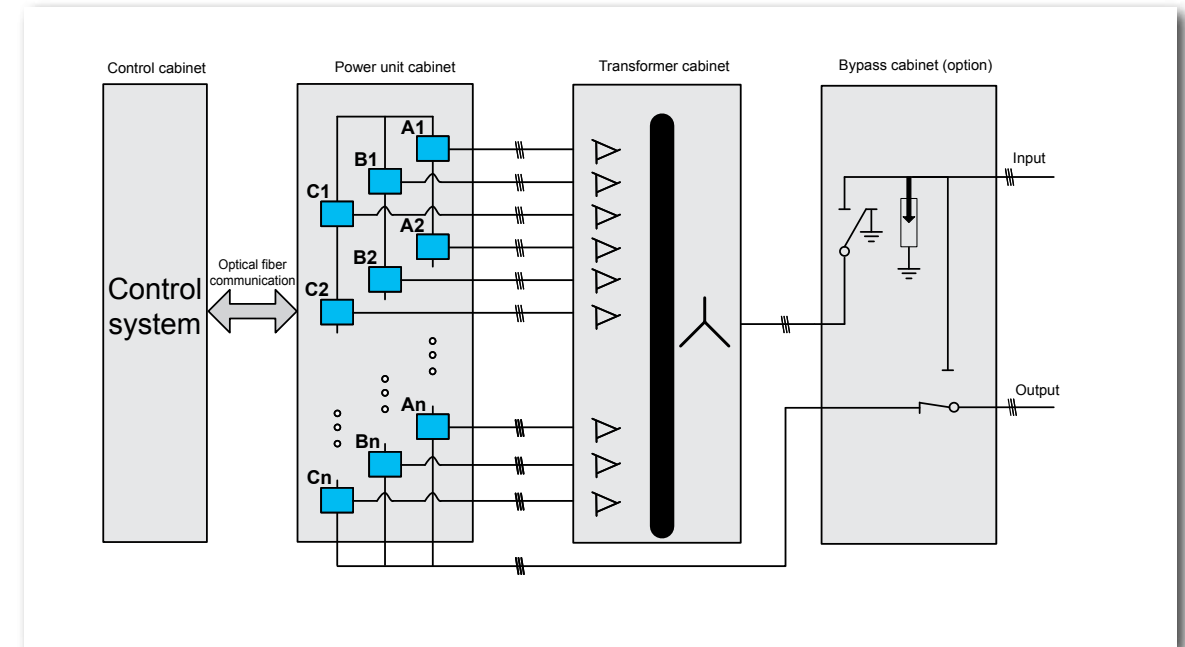

### Modular System

Each output phase consists of multiple power modules connected in series to achieve the required output voltage level.

System Voltage	Cells/phase	Phase-shift transformer (pulses)
3.3kV	3	18
4.16kV	4	24
6kV	6	36
6.6kV	6	36
10kV	9	54
11kV	10	60

Cascaded Output Voltage Map

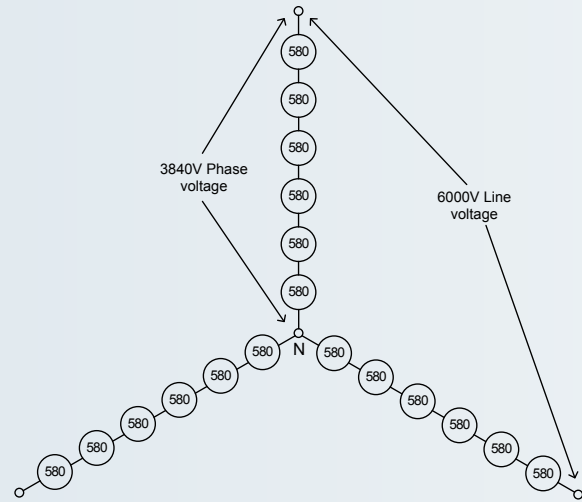

Power Unit Schematic Diagram

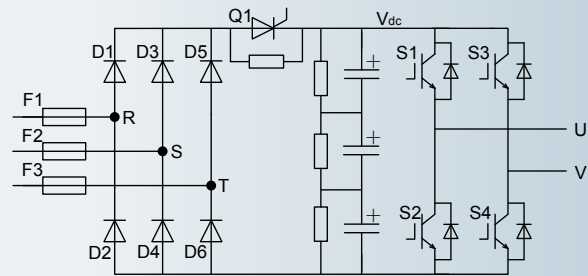

## MVD2000 Specifications & Parameters

MVD2000		
System Technology	Cascaded multilevel inverter based on IGBT devices	
Efficiency	>98% (Rated, excluding transformer)	
Input	Voltage range	-10%~+10% (normal operation), -10%~-30% (continuous running at derated speed)
	Frequency	50Hz/60Hz (-2%~+2%)
	Control power supply	AC380 V (three-phase four-wire system) or AC220V, 3kVA single-ohase capacity
	Input current harmonic	Meets IEEE519 standard, without input filter
	Power factor	>0.96 (lagging at rated speed and power)
Output	Voltage	3.3kV~11kV
	Max. output frequency	75Hz
	Overload capacity	150% per min/10 min. (standard), other options available
	Start-up torque	150% rated torque (standard), other options available
	Speed regulation range	1%~100% (with encoder) , 5%~100% (without speed sensor)
	Speed control resolution (steady state)	±0.01% (with speed sensor, depending on sensor accuracy), ±0.5% (without speed sensor)
	Speed response bandwidth	60rad/s (with speed sensor), 20rad/s (without speed sensor)
Current response bandwidth	600rad/s	
Control Parameters	Control methods	Vector control with encoder and encoderless
	Modulation method	SVPWM
	Acceleration & deceleration time	0~3000s (programmable)
	Alarms	Power cell under-voltage, analog reference loss, cooling fan over-temperature, cooling fan power supply failure, cabinet over-pressure, air filter blocked, control power supply failure, transformer high-temperature, HMI communication failure, ac input under-voltage, UPS failure, PLC communication failure, flying start failure
	Protections	Over-current, over-load, short-circuit, input over-voltage, input/output phase loss, input voltage power loss, output fault to ground, transformer over-temperature, power cell communication failure, optical fiber communication failure, high-voltage cabinet door open, control power supplies failures, dc auxiliary power supply failure, power cell over-temperature, power cell over-voltage, power cell IGBT gate drive failure, over-speed protection, under-speed protection, reverse rotation protection, motor stall protection
	Functions	Speed skipping, PID regulator, fault event log, flying start, power loss ride through, automatic restart, auto-tuning, S-curve acceleration, adaptive acceleration and deceleration, DC braking current injection, forward/reverse rotation selection, jogging, system bypass, synchronous motor transfer option, master-slave control
	Analog input	0~10V/4~20mA, two channels (expandable)
	Analog output	0~10V/4~20mA , four channels, (expandable)
	Digital input / output	10-channel input, 8-channel output (expandable)
	Human machine interface	Chinese/English touch-screen LCD display





Control Parameters	Display parameters	Reference speed, output speed, input/output current, operating status indication
	Communication interface	Isolated RS485, industrial Ethernet (option), GPRS (option)
	Communication protocol	MODBUS, PROFIBUS, other options
Environment	Operating temperature	-5°C~+40°C (normal operation); +40°C~+50°C (de-rating operation)
	Storage/transportation temperature	-40°C~+70°C
	Relative humidity	5%~95%, no condensation
	Altitude	<1000m
Structure	Dimension & quality	Refer to the spec list
	Color	RAL7035 (or customized )
Cooling method	Forced air cooling	
Protection level	IP30 (standard), other configurations can be customized	



## Standards

Standard No.	Standard Title
GB/T 156-2007	Standard Voltages
GB/T 1980-2005	Standard Frequencies
GB/T 2423.10-2008	Environmental testing for electric and electronic products - Part 2: Test methods - Test Fc: Vibration (sinusoidal)
GB 2681-81	Colors of insulated conductors used in electrical assembly devices
GB 2682-1981	Colors of indicator lights and push-buttons used in electrical assembly devices
GB/T 3797-2005	Electrical control assemblies
GB/T 3859.1-93	Semiconductor convertors - Specification of basic requirements
GB/T 3859.2-93	Semiconductor convertors - Application guide
GB/T 3859.3-93	Semiconductor convertors - Transformers and reactors
GB 4208-2008	Degrees of protection provided by enclosures (IP code)
GB/T 4588.1-1996	Sectional specification: Single and double sided printed boards without plain holes
GB/T 4588.2-1996	Sectional specification: single and double sided printed boards with plated-through holes
GB 7678-87	Semiconductor self - commutated convertors
GB/T 10233-2005	Basic testing method for low-voltage switchgear and control-gear assemblies
GB 12668-90	General specification for speed control assembly with semiconductor adjustable frequency for A.C. motor
GB/T 15139-94	General technical standard for electrical equipment structure
GB/T 13422-92	Power semiconductor convertors—Electrical test methods
GB/T 14549-93	Quality of electric energy supply—Harmonics in public supply network
GB/T 12668.3-2003	Adjustable speed electrical power drive systems Part 3: EMC product standard including specific test methods
GB/T 12668.4-2006	Adjustable speed electrical power drive systems—Part 4: General requirements—Rating specifications for A.C. power drive systems above 1000 V A.C. not exceeding 35 kV
IEEE 519-1992	IEEE recommended practices and requirements for harmonic control in electrical power systems
IEC 60038	IEC standard voltages
IEC 60076-1	Power transformers - Part 1: General



IEC 60076-11	Power transformers - Part 11: Dry-type transformers
IEC 60076-12	Power transformers - Part 12: Loading guide for dry-type power transformers
IEC 60076-2	Power transformers - Part 2: Temperature rise
IEC 60076-3	Power transformers - Part 3: Insulation levels, dielectric tests and external clearances in air
IEC 60721-3-1	Classification of environmental conditions - Part 3 Classification of groups of environmental parameters and their severities - Section 1: Storage
IEC 60721-3-2	Classification of environmental conditions - Part 3: Classification of groups of environmental parameters and their severities - Section 2: Transportation
IEC 60721-3-3	Classification of environmental conditions - Part 3: Classification of groups of environmental parameters and their severities - Stationary use at weather protected locations
IEC 61000-2-4	Electromagnetic compatibility (EMC) - Part 2-4: Environment - Compatibility levels in industrial plants for low-frequency conducted disturbances
IEC 61800-3	Adjustable speed electrical power drive systems - Part 3: EMC requirements and specific test methods
IEC 61800-4	Adjustable speed electrical power drive systems - Part 4: General requirements - Rating specifications for a.c. power drive systems above 1000V a.c. and not exceeding 35kV
IEC 61800-5-1	Adjustable speed electrical power drive systems - Part 5-1: Safety requirements - Electrical, thermal and energy



## Product Dimensions

6kV MVD2000 outline drawings shown below:

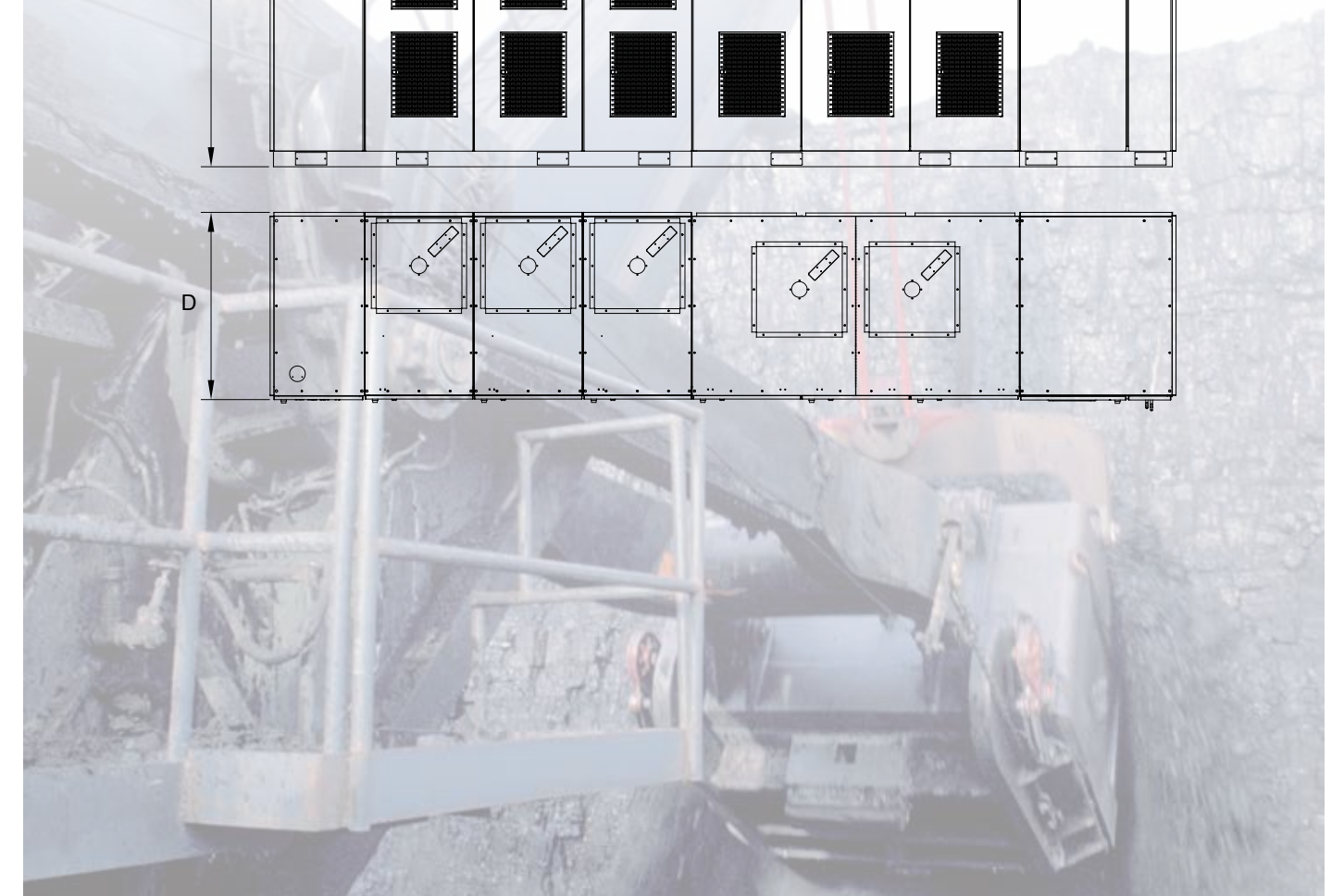
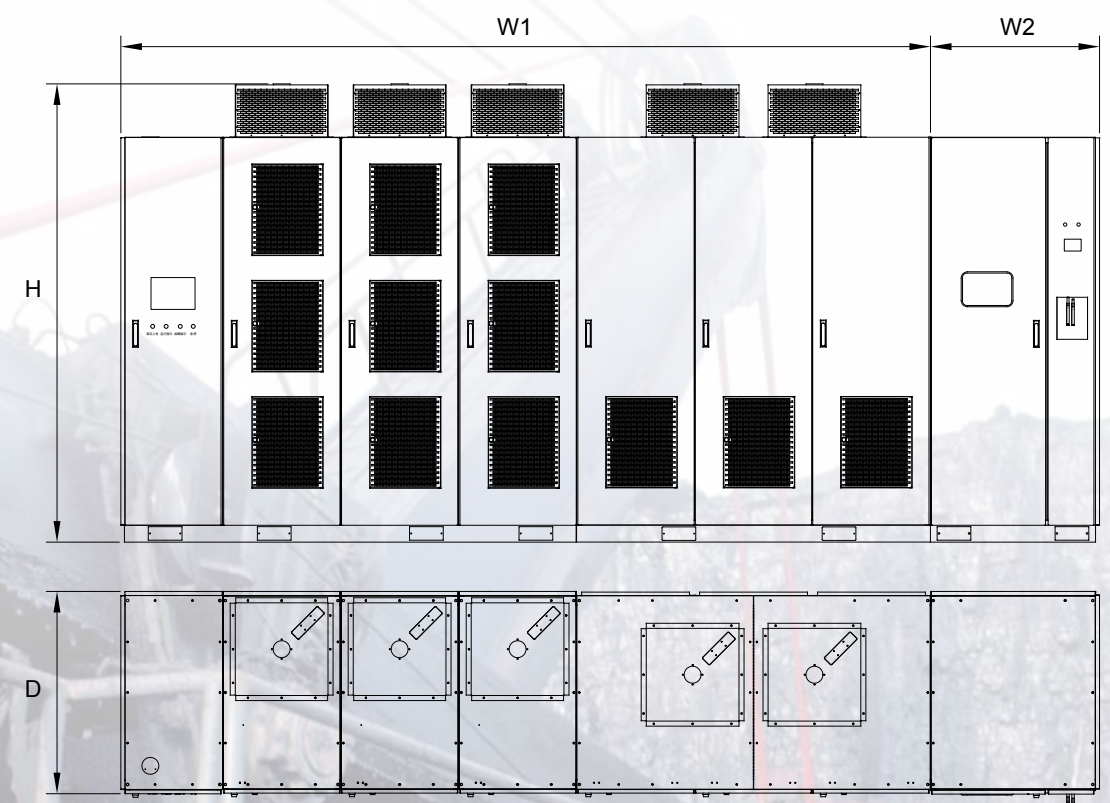

## Product Selection

MVD2000								
Rated Voltage (kV)	Rated Output Current (A)		Motor Shaft Power (kW)		Cabinet Dimensions (H×W1×D) (mm)	Weight (kg)	Bypass Canbinet(Optional)	
	CT	VT	Constant Torque Load	Variable Torque Load			Width W2 (mm)	Weight (kg)
3.3	40	50	183	229	2400x2800x1200	2500	1030	800
	56	70	256	320		3100	1030	800
	96	120	439	549		5000	1030	800
	152	190	695	869	2700x3430x1200	6000	1030	800
	200	250	914	1143	2700x3800x1200	7400	1030	800
	244	305	1116	1395	2700x4100x1400	8500	1030	800
	350	438	1600	2003	2700x4850x1400	9500	1030	800
	448	560	2048	2561	2700x5450x1400	10500	1030	800
	544	680	2488	3109	2782x6200x1400	11500	1030	800
	672	840	3073	3841	2782x6200x1400	12000	1030	800
4.16	40	50	231	288	2400x3100x1200	2600	1030	800
	56	70	323	403		3200	1030	800
	96	120	553	692		5100	1030	800
	152	190	876	1095	2700x3730x1200	6100	1030	800
	200	250	1153	1441	2700x4100x1200	7500	1030	800
	244	305	1406	1758	2700x4400x1400	8600	1030	800
	350	438	2017	2525	2700x5400x1400	9500	1030	800
	448	560	2582	3228	2700x6000x1400	10400	1030	800
	544	680	3136	3920	2782x6900x1400	11600	1030	800
	672	840	3874	4842	2782x6900x1400	13500	1030	800
6	40	50	333	416	2400x3800x1200	3000	1030	800
	56	70	466	582		3600	1030	800
	96	120	798	998		5500	1030	800
	152	190	1264	1580	2740x4430x1200	6500	1030	800
	200	250	1663	2078	2740x4800x1200	7900	1030	800
	244	305	2029	2536	2740x5100x1400	8900	1030	900
	350	438	2910	3641	2740x7180x1450	10500	1030	950
	448	560	3724	4656	2900x8000x1550	12000	1030	1050
	544	680	4523	5653	2900x8000x1600	13200	1030	1050
	672	840	5587	6984	2900x8000x1600	14000	1030	1050

CT: Constant torque  
VT: Variable torque

MVD2000								
Rated Voltage (kV)	Rated Output Current (A)		Motor Shaft Power (kW)		Cabinet Dimensions (H×W1×D) (mm)	Weight (kg)	Bypass Canbinet(Optional)	
	CT	VT	Constant Torque Load	Variable Torque Load			Width W2 (mm)	Weight (kg)
6.6	40	50	366	457	2400x3800x1200	3000	1030	1050
	56	70	512	640		3600	1030	1050
	96	120	878	1097		5500	1030	1050
	152	190	1390	1738	2700x4430x1200	6500	1030	1050
	200	250	1829	2286	2700x4800x1201	7900	1030	1050
	244	305	2231	2789	2700x5100x1202	8900	1030	1050
	350	438	3201	4005	2700x6600x1203	9800	1030	1050
	448	560	4097	5121	2700x7800x1204	10700	1030	1050
	544	680	4975	6219	2782x6900x1400	11300	1030	1050
	672	840	6146	7682	2782x6900x1400	12500	1030	1050
10	40	50	554	693	2400x4800x1200	4700	1030	800
	56	70	776	970	2700x4800x1200	5600	1030	800
	96	120	1330	1663		7100	1030	800
	152	190	2106	2633	2740x5550x1450	9000	1030	950
	200	250	2771	3464	2850x5850x1450	11600	1030	950
	244	305	3381	4226	2740x5850x1450	12800	1030	950
	350	438	4850	6069	2740x9280x1500	13500	1030	1000
	448	560	6207	7759	2900x10400x1550	14000	1030	1050
	544	680	7538	9422	2900x11400x1600	15600	1030	1050
	672	840	9312	11639	2900x11400x1600	17300	1030	1050
11	40	50	610	762	2400x5100x1200	4800	1030	1050
	56	70	854	1067	2700x5100x1200	5700	1030	1050
	96	120	1463	1829		7200	1030	1050
	152	190	2317	2896	2700x5850x1450	9100	1030	1050
	200	250	3048	3810	2850x6150x1450	11700	1030	1050
	244	305	3719	4649		12900	1030	1050
	350	438	5335	6676	2850x9900x1450	13900	1030	1050
	448	560	6828	8535	2850x11900x1450	15000	1030	1050
	544	680	8292	10365	2900x12500x1600	16800	1030	1050
	672	840	10243	12803	2900x12500x1600	19000	1030	1050



## Installation Diagram

### Installation foundation

For wiring safety and convenience, it is recommended to install the MVD cabinet on a cable trench as shown in the drawing below.

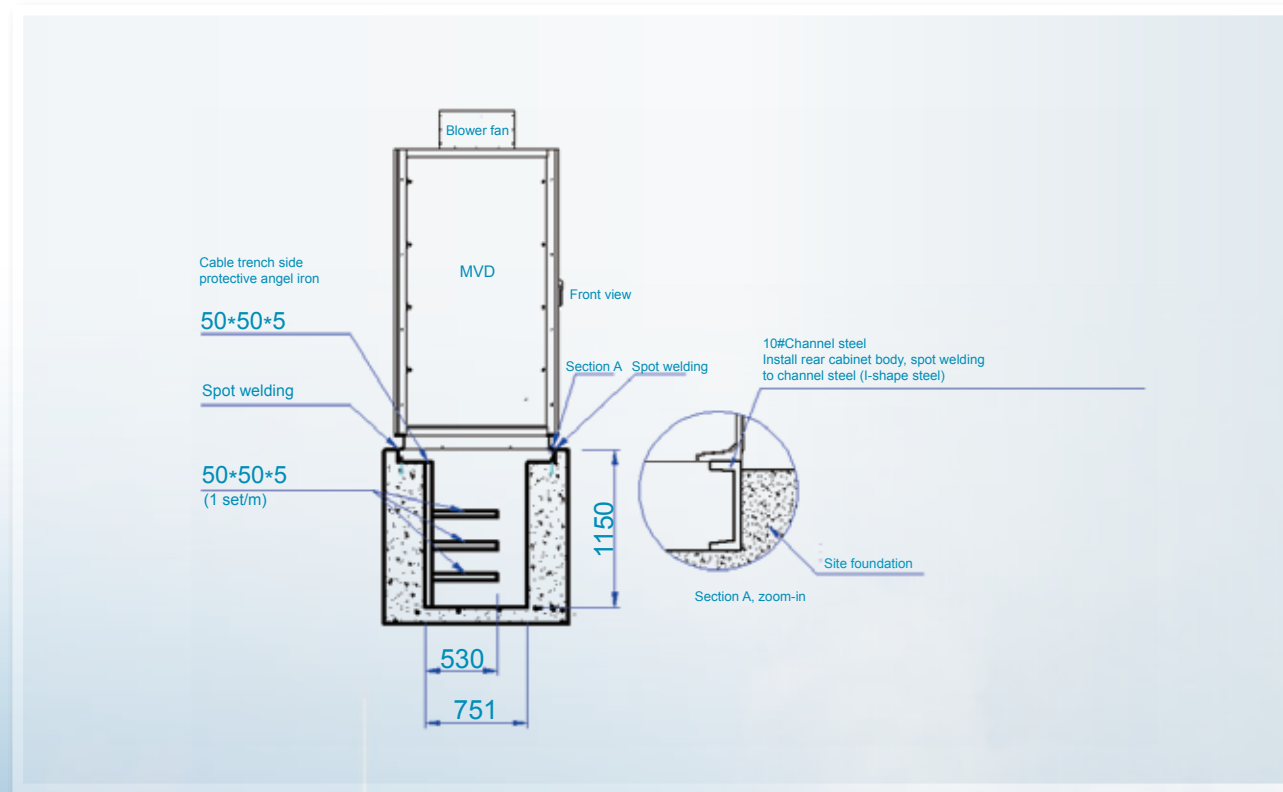

Cross section of cable and installation trench

### Detail requirements:

1. It is recommended to set the minimum length of cable trench as the total MVD length, adding 1m to the left and right for easy cabling and maintenance.
2. The MVD is placed on the trench rail using 10# channel steel (use 16# channel steel if the MVD power is  $\geq 1600\text{kW}$  and 18# double-T steel if the MVD power is  $\geq 4000\text{kW}$ ).
3. Reserve free space on top and front of the MVD cabinet, so that the distance between cabinet top and ceiling is  $\geq 800\text{mm}$ , and the distance between cabinet front and walls is  $\geq 1500\text{mm}$ .
4. For ventilation and maintenance convenience, the distance from the rear of the dry-type transformer cabinet and the back wall shall be  $\geq 1000\text{mm}$ .

## MVD Cooling Proposal

There are three possible cooling solutions which are open-air-duct cooling, sealed air conditioning cooling, and air conditioning with air-duct cooling.

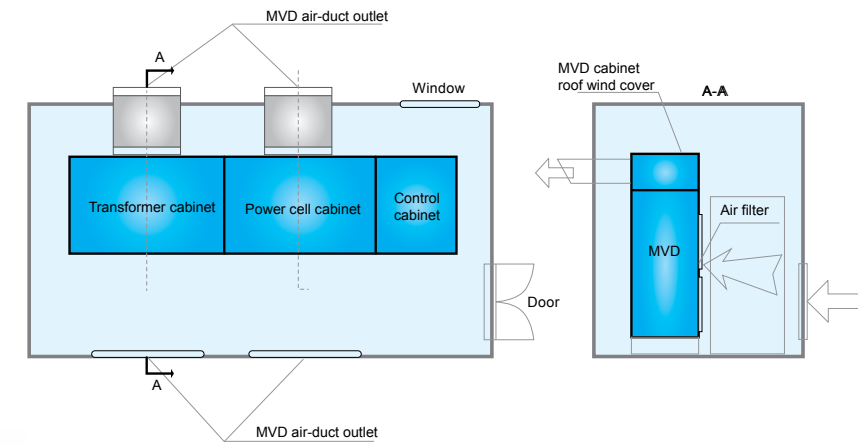

Open-air-duct cooling

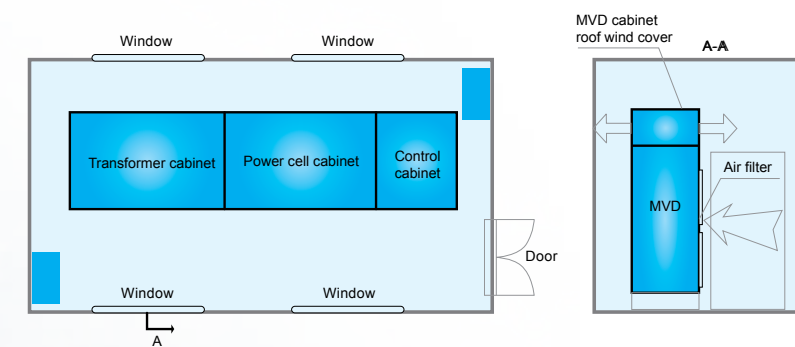

Sealed-air-conditioning cooling

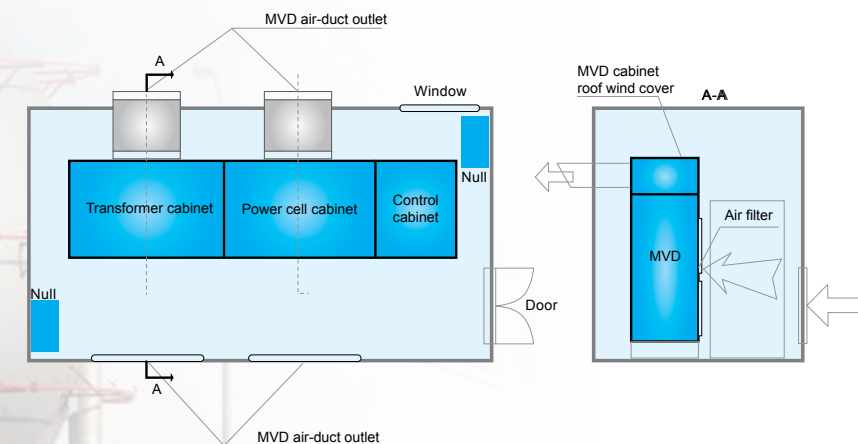

Air-duct & air-conditioning cooling

## Reliability & Certification

Delta provides quality assurance through rigorous inspection and testing based on international standards. To ensure that the drive operates as predicted upon start-up, Delta Electronics has built a state-of-the-art, multi-megawatt test facility for full load capacity and full load burn-in verification. A detailed test procedure reduces start-up time during installation and commissioning in the field.

### Advanced test methods and equipment



• High Voltage Distribution Cabinet



• Low voltage inverter (re-generation)



• Central control room



• Burn-in Chamber



• Thermal Chamber



• Motor-Generator Groups

### International certificates



ISO 9001:2008



ISO 14001:2004



OHSAS 18001:2007



QC 080000:2007



TL 9000 R5.0



CE (EMC)

## System Model Names

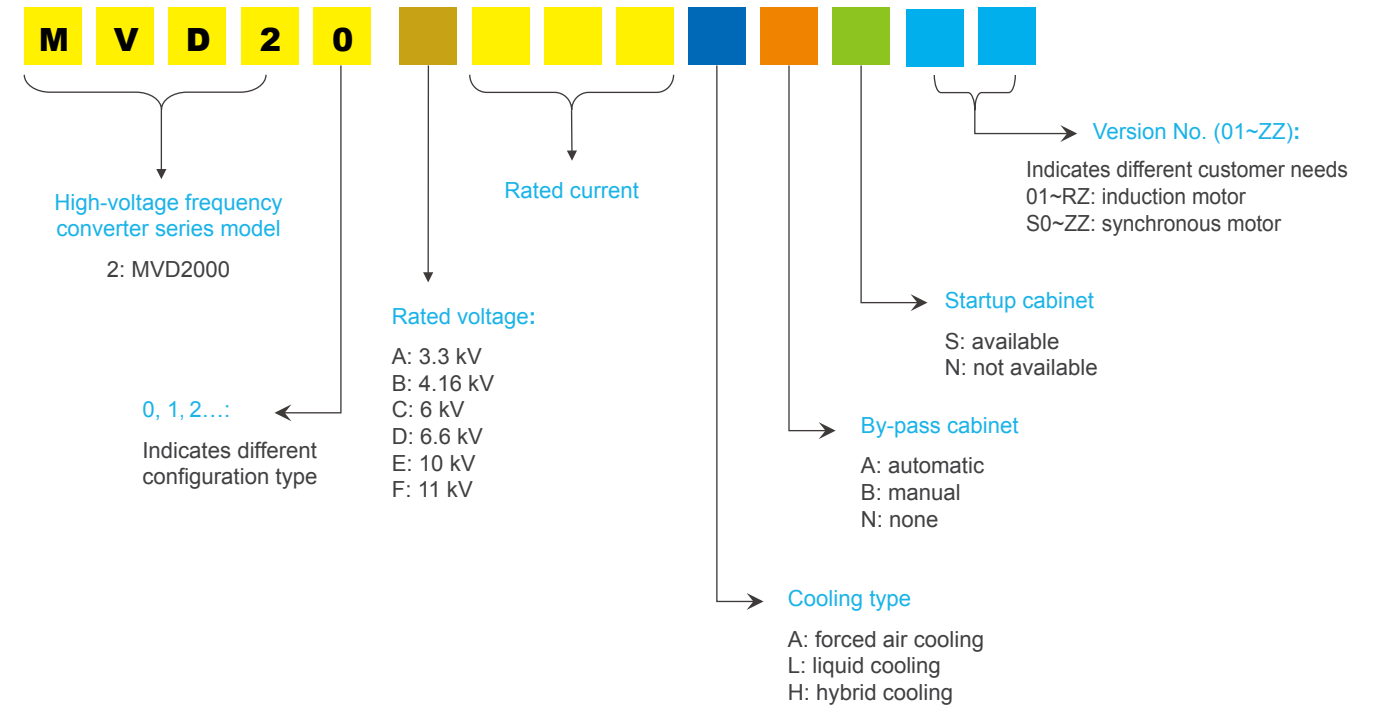

## Global Sales & Service

The warranty period is one year counted from receiving the equipment at customer's site. During the warranty period, Delta will provide replacement of defective parts and repairs. Worldwide service capability ensures response in less than 8 hours, arrival at site in less than 24 hours and troubleshooting in less than 48 hours.







Transmisiones Ltda. Carrera 68 B # 21 A -  
24, bodega UE 28- 1 Parque Industrial  
Montevideo PBX: (57+1) 4126898  
Bogotá - Colombia  
info@ transmisiones.de  
www, transmisiones.de

More information of products and sales, please consult: [mvd@delta.com.tw](mailto:mvd@delta.com.tw)

[www.deltaww.com/mvd](http://www.deltaww.com/mvd)

20130312