



# Delta AC Motor Drive

## VFD-F Series → CP2000 Series

### Product Replacement Guide

# VFD-F Series → CP2000 Series

## Product Replacement Guide

### Table of Content

01 Comparison of Dimensions-----	Page1-1
02 Comparison of Keypads-----	Page2-1
03 Comparison of Terminals-----	Page3-1
04 Comparison of Wiring Diagrams-----	Page4-1
05 CP2000 Derating-----	Page5-1
06 CP2000 Optional Accessories-----	Page6-1
07 Comparison of Parameters-----	Page7-1

## 01- Comparison of Dimensions

Voltage	VFD-F Models	CP2000 Models	VFD-F			CP2000		
			W	H	D	W	H	D
220V Models	VFD007F23A	VFD007CP23A-21	150.0 [5.91]	135 [5.32]	260.0 [10.24]	130.0 [5.12]	250.0 [9.84]	170.0 [6.69]
	VFD015F23A	VFD015CP23A-21						
	VFD022F23A	VFD022CP23A-21						
	VFD037F23A	VFD037CP23A-21						
	VFD055F23A	VFD055CP23A-21	200.0 [7.88]	323.0 [12.72]	183.2 [7.22]	190.0 [7.48]	320.0 [12.60]	190.0 [7.48]
	VFD075F23A	VFD075CP23A-21						
	VFD110F23A	VFD110CP23A-21						
	VFD150F23A	VFD150CP23A-21	250.0 [9.84]	403.8 [15.90]	205.4 [8.08]	250.0 [9.84]	400.0 [15.75]	210.0 [8.27]
	VFD185F23A	VFD185CP23A-21						
	VFD220F23A	VFD220CP23A-21						
	VFD300F23A	VFD300CP23A-21	370.0 [14.57]	589.0 [23.19]	260.0 [10.24]	330.0 [12.99]	688.3 [27.10]	275.0 [10.83]
	VFD370F23A	VFD370CP23A-21						
	-	VFD450CP23A-21	-	-	-	370.0 [14.57]	715.8 [28.18]	300.0 [11.81]
	-	VFD550CP23A-21						
-	VFD750CP23A-21							
-	VFD900CP23A-21							

Unit: mm [inch]

Voltage	VFD-F Models	CP2000 Models	VFD-F			CP2000		
			W	H	D	W	H	D
460V Models	VFD007F43A	VFD007CP43A-21	150.0 [5.91]	135 [5.32]	260.0 [10.24]	130.0 [5.12]	250.0 [9.84]	170.0 [6.69]
	VFD015F43A	VFD015CP43A-21						
	VFD022F43A	VFD022CP43A-21						
	VFD037F43A	VFD037CP43A-21						
	VFD055F43A	VFD055CP43A-21	200.0 [7.88]	323.0 [12.72]	183.2 [7.22]	190.0 [7.48]	320.0 [12.60]	190.0 [7.48]
	VFD075F43A	VFD075CP43A-21						
	VFD110F43A	VFD110CP43A-21						
	VFD150F43A	VFD150CP43A-21	250.0 [9.84]	403.8 [15.90]	205.4 [8.08]	250.0 [9.84]	400.0 [15.75]	210.0 [8.27]
	VFD185F43A	VFD185CP43A-21						
	VFD220F43A	VFD220CP43A-21						
	VFD300F43A	VFD300CP43A-21	370.0 [14.57]	595.0 [23.43]	26.0 [10.24]	330.0 [12.99]	688.3 [27.10]	275.0 [10.83]
	VFD370F43A	VFD370CP43A-21						
	VFD450F43A	VFD450CP43A-21	370.0 [14.57]	589.0 [23.19]	26.0 [10.24]	370.0 [14.57]	715.8 [28.18]	300.0 [11.81]
	VFD550F43A	VFD550CP43A-21						
	VFD750F43A	VFD750CP43A-21						
	VFD900F43C	VFD900CP43A-21						
	VFD1100F43C	VFD1100CP43A-21	425.0 [16.73]	850.0 [33.46]	264.0 [10.39]	370.0 [14.57]	715.8 [28.18]	300.0 [11.81]
	VFD1320F43A	VFD1320CP43A-21						
	VFD1600F43A	VFD1600CP43A-21	547.0 [21.54]	1357.6[5 3.45]	360.0 [14.17]	420.0 [12.54]	940.0 [37.00]	300 [11.81]
	VFD1850F43A	VFD1850CP43A-21						
VFD2200F43A	VFD2200CP43A-21							
-	VFD2800CP43A-21	-	-	-	500.0 [16.69]	1240.2[4 8.83]	397.0 [15.63]	
-	VFD3150CP43C-21							
-	VFD3550CP43C-21							
-	VFD4000CP43C-21							

Unit: mm [inch]

## 02 - Comparison of Keypads

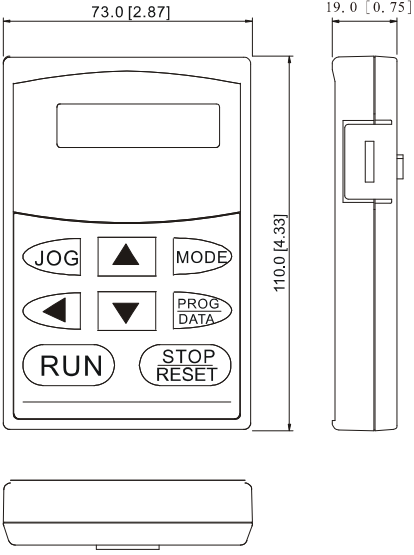
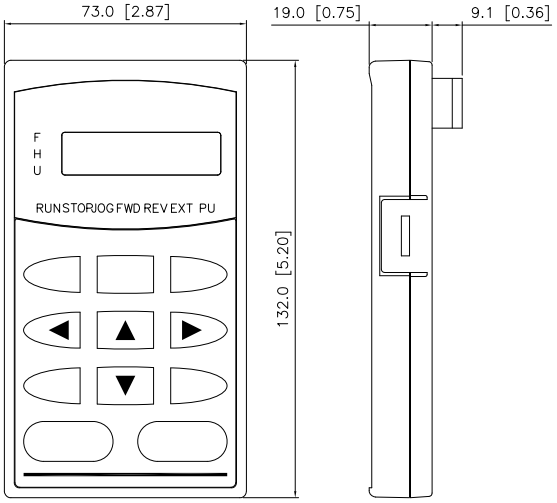
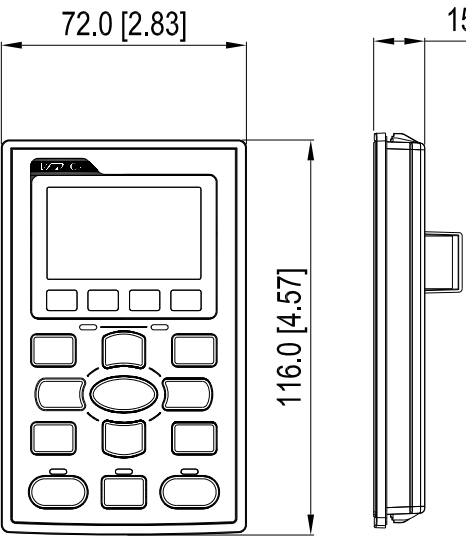
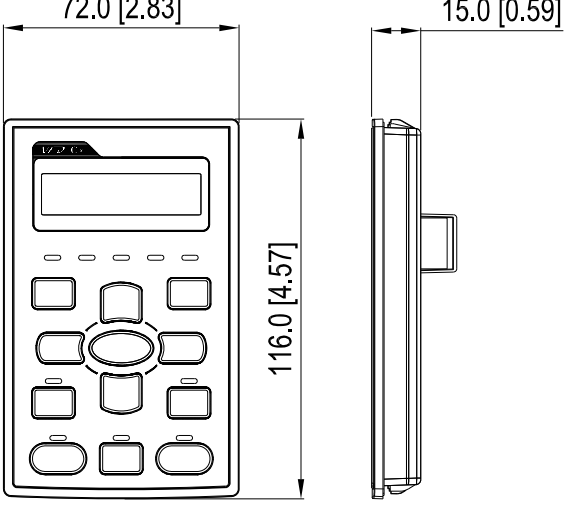
Model	Standard	Optional
VFD-F	<p data-bbox="280 331 703 365">Digital Keypad VFD-PU01Dimensions</p> 	<p data-bbox="890 331 1313 365">Digital Keypad KPF-CC01Dimensions</p> 
CP2000	<p data-bbox="280 981 703 1014">Digital Keypad KPC-CC01Dimensions</p> 	<p data-bbox="890 981 1313 1014">Digital Keypad KPC-CE01 Dimensions</p> 

Unit: mm [inch]

## ◆ Intallation of CP2000 Digital Keypad

### ▲ Panel Mounting Kit (MKC-KPPK)

For MKC-KPPK model, user can choose wall mounting or embedded mounting, protection level is IP56.

Applicable to the digital keypads (KPC-CC01 & KPC-CE01).

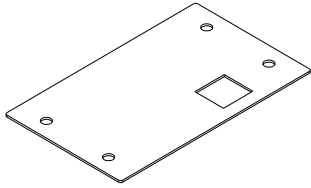
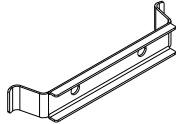
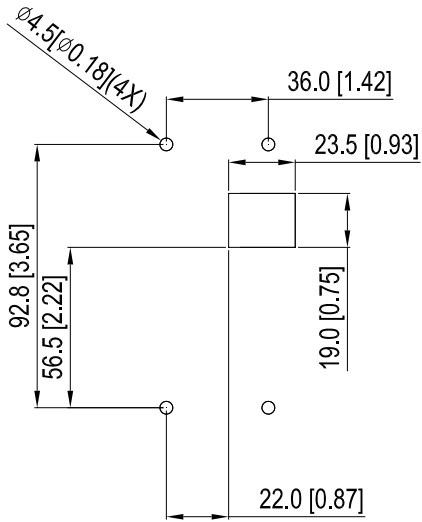
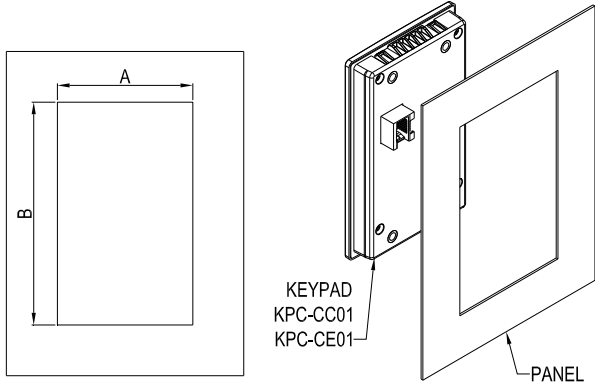
Wall Mounting	Embedded Mounting												
accessories*1 	accessories*2 												
Screw *4 ~M4*p 0.7 *L8mm Torque: 10-12kg-cm (8.7-10.4lb-in.)	Screw *4 ~M4*p 0.7 *L8mm Torque: 10-12kg-cm (8.7-10.4lb-in.)												
Panel cutout dimension      Unit: mm [inch]	Panel cutout dimension      Unit: mm [inch]												
													
	Normal cutout dimension <table border="1" style="width: 100%; text-align: center;"> <tr> <td>Panel thickness</td> <td>1.2mm</td> <td>1.6mm</td> <td>2.0mm</td> </tr> <tr> <td>A</td> <td colspan="3">66.4 [2.614]</td> </tr> <tr> <td>B</td> <td>110.2 [4.339]</td> <td>111.3 [4.382]</td> <td>112.5 [4.429]</td> </tr> </table> <p style="text-align: right;">*Deviation: ±0.15mm /±0.0059inch</p>	Panel thickness	1.2mm	1.6mm	2.0mm	A	66.4 [2.614]			B	110.2 [4.339]	111.3 [4.382]	112.5 [4.429]
Panel thickness	1.2mm	1.6mm	2.0mm										
A	66.4 [2.614]												
B	110.2 [4.339]	111.3 [4.382]	112.5 [4.429]										
	Cutout dimension (Waterproof level: IP56) <table border="1" style="width: 100%; text-align: center;"> <tr> <td>Panel thickness</td> <td>1.2mm</td> <td>1.6mm</td> <td>2.0mm</td> </tr> <tr> <td>A</td> <td colspan="3">66.4 [2.614]</td> </tr> <tr> <td>B</td> <td colspan="3">110.8 [4.362]</td> </tr> </table> <p style="text-align: right;">*Deviation: ±0.15mm /±0.0059inch</p>	Panel thickness	1.2mm	1.6mm	2.0mm	A	66.4 [2.614]			B	110.8 [4.362]		
Panel thickness	1.2mm	1.6mm	2.0mm										
A	66.4 [2.614]												
B	110.8 [4.362]												

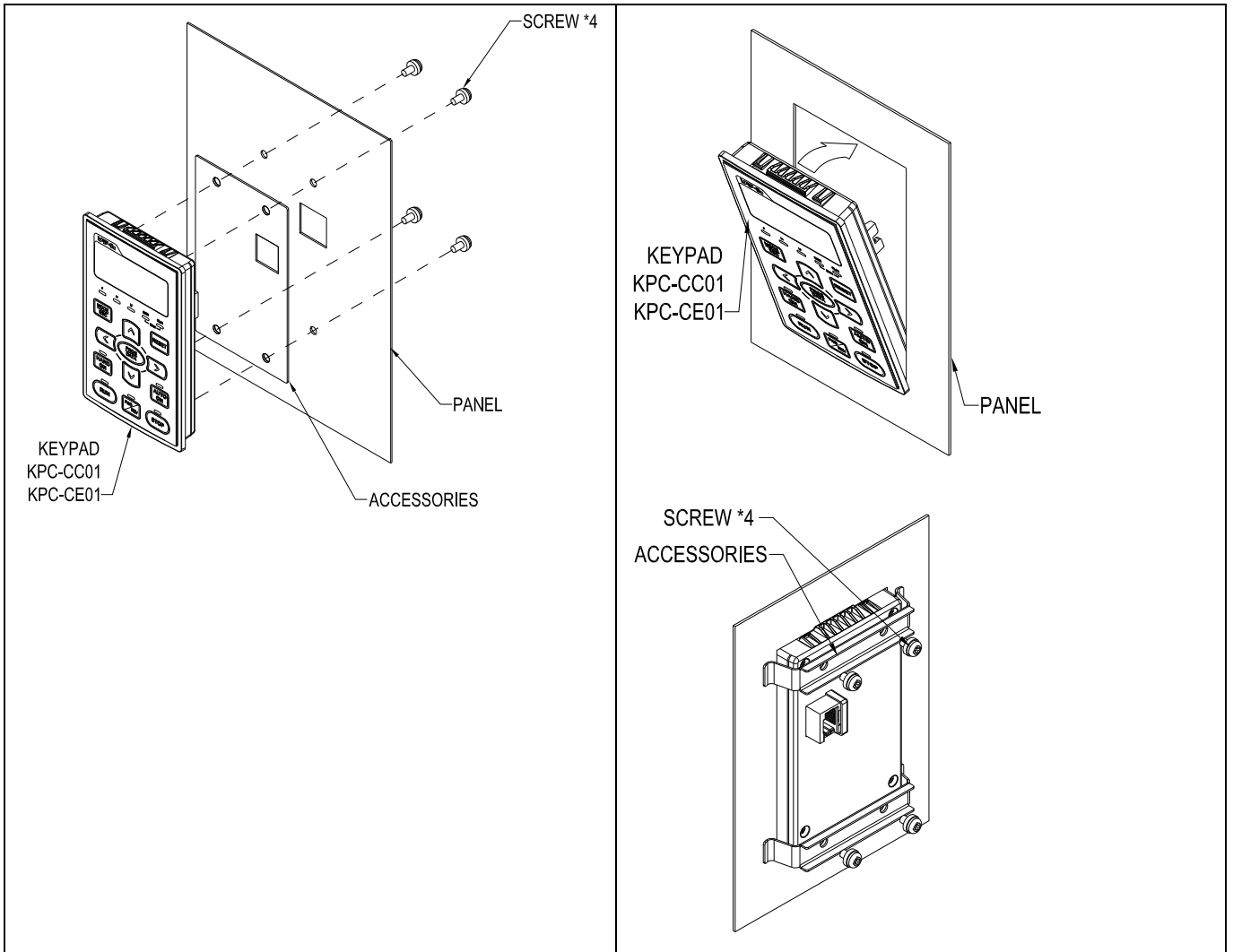

## 03 - Comparison of Terminals

VFD-F			VFD-CP2000		
Terminals	Terminal Function	Factory Setting (NPN mode)	Terminals	Terminal Function	Factory Setting (NPN mode)
+24V	Digital control signal common (Source)	+24V 20mA	+24V	Digital control signal common (Source)	+24V±5% 200mA
DCM	Digital control signal common (Sink)	Common for multi-function input terminals	COM	Digital control signal common (Sink)	Common for multi-function input terminals
FWD	Forward-Stop command	—	FWD	Forward-Stop command	FWD-DCM: ON: forward running OFF: deceleration to stop
REV	Reverse-Stop command	—	REV	Reverse-Stop command	REV-DCM: ON: reverse running OFF: deceleration to stop
MI1	Multi-function input 1	Factory setting: Multi-step speed command 1	MI1	Multi-function input 1	Refer to parameters 02-01~02-08 to program the multi-function inputs MI1~MI8. ON: the activation current is 6.5mA ≥ 11Vdc OFF: leakage current tolerance is 10μA ≤ 11Vdc
MI2	Multi-function input 2	Factory setting: Multi-step speed command 2	MI2	Multi-function input 2	
MI3	Multi-function input 3	Factory setting: Multi-step speed command 3	MI3	Multi-function input 3	
MI4	Multi-function input 4	Factory setting: Multi-step speed command 4	MI4	Multi-function input 4	
MI5	Multi-function input 5	Factory setting: RESET	MI5	Multi-function input 5	
MI6	Multi-function input 6	Factory setting: JOG	MI6	Multi-function input 6	
MI7	Multi-function input 7	Factory setting: Accel/Decel prohibit	MI7	Multi-function input 7	
MI8	Multi-function input 8	Factory setting: Accel/Decel time switch 1	MI8	Multi-function input 8	
—	—	—	DCM	Digital frequency signal common	—
EF	External fault	—	—	—	—

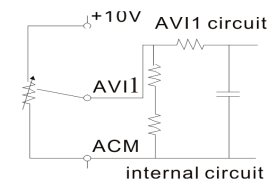
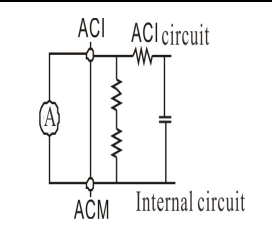
VFD-F			VFD-CP2000		
Terminals	Terminal Function	Factory Setting (NPN mode)	Terminals	Terminal Function	Factory Setting (NPN mode)
RA1	Multi-function Relay1 output (N.O.) a	1.5A(N.O.)/1A(N.C.) 240VAC; 1.5A(N.O.)/1A(N.C.) 24VDC; Refer to Pr.03-00 to Pr.03-01	RA1	Multi-function relay output 1 (N.O.) a	Resistive Load: 5A(N.O.)/3A(N.C.) 250VAC 5A(N.O.)/3A(N.C.) 30VDC;  Inductive Load (COS 0.4): 2.0A(N.O.)/1.2A(N.C.) 250VAC; 2.0A(N.O.)/1.2A(N.C.) 30VDC;  It is to output each monitoring signal, such as drive is in operation, frequency attained or overload indication.
RB1	Multi-function Relay1 output (N.C.) b		RB1	Multi-function relay output 1 (N.C.) b	
RC1	Multi-function Relay1 common		RC1	Multi-function relay common (Relay)	
RA2	Multi-function Relay2 output (N.O.) a		RA2	Multi-function relay output 2 (N.O.) a	
RB2	Multi-function Relay2 output (N.C.) b		—	—	
RC2	Multi-function Relay2 common		RC2	Multi-function relay common (Relay)	
—	—	—	RA3	Multi-function relay output 3 (N.O.) a	
—	—	—	RC3	Multi-function relay common (Relay)	
+10V	Potentiometer power source	+10V 20mA	+10V	Potentiometer power supply	Analog frequency setting: +10Vdc 20mA
AVI	Analog voltage Input	0 to +10V correspond to Max. operation frequency	AVI1	Analog voltage input 	Impedance: 20kΩ; Range: 0~ 20mA/0~10V =0~ Max. Output Frequency (Pr.01-00); AVI switch, factory setting is 0~10V;
ACI1/2	Analog current Input	4 to 20mA correspond to Max. operation frequency	ACI	Analog current input 	Impedance: 250Ω; Range: 0 ~ 20mA/0~10V=0~ Max. Output Frequency (Pr.01-00); ACI Switch, factory setting is 0~20mA;

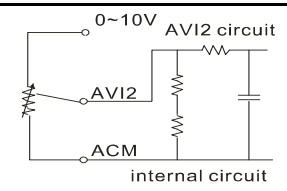
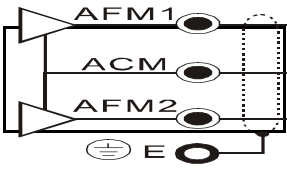

VFD-F			VFD-CP2000		
Terminals	Terminal Function	Factory Setting (NPN mode)	Terminals	Terminal Function	Factory Setting (NPN mode)
—	—	—	AVI2	Auxiliary analog voltage input 	Impedance: 20kΩ; Range: 0 ~ +10VDC=0~ Max. Output Frequency (Pr.01-00);
AFM1	Analog frequency / current meter 1	0 to 10V correspond to Max. operation frequency	AFM1		Impedance: 100Ω (current output); Output current: 20mA max; Resolution: 0~10V corresponds to Max. operation frequency; Range: 0~10V à 0~20mA; AFM Switch: factory setting is 0~10V;
AFM2	Analog frequency / current meter 2	4 to 20mA correspond to 2 times of output current	AFM2		
ACM	Analog control signal (common)	—	ACM	Analog Signal Common	Common for analog terminals
—	—	—	S1	Factory setting: short-circuit	
—	—	—	SCM	Power removal safety function for emergency stop.	

# 04 - Comparison of Wiring Diagrams

## ◆ VFD-F Wiring Diagram

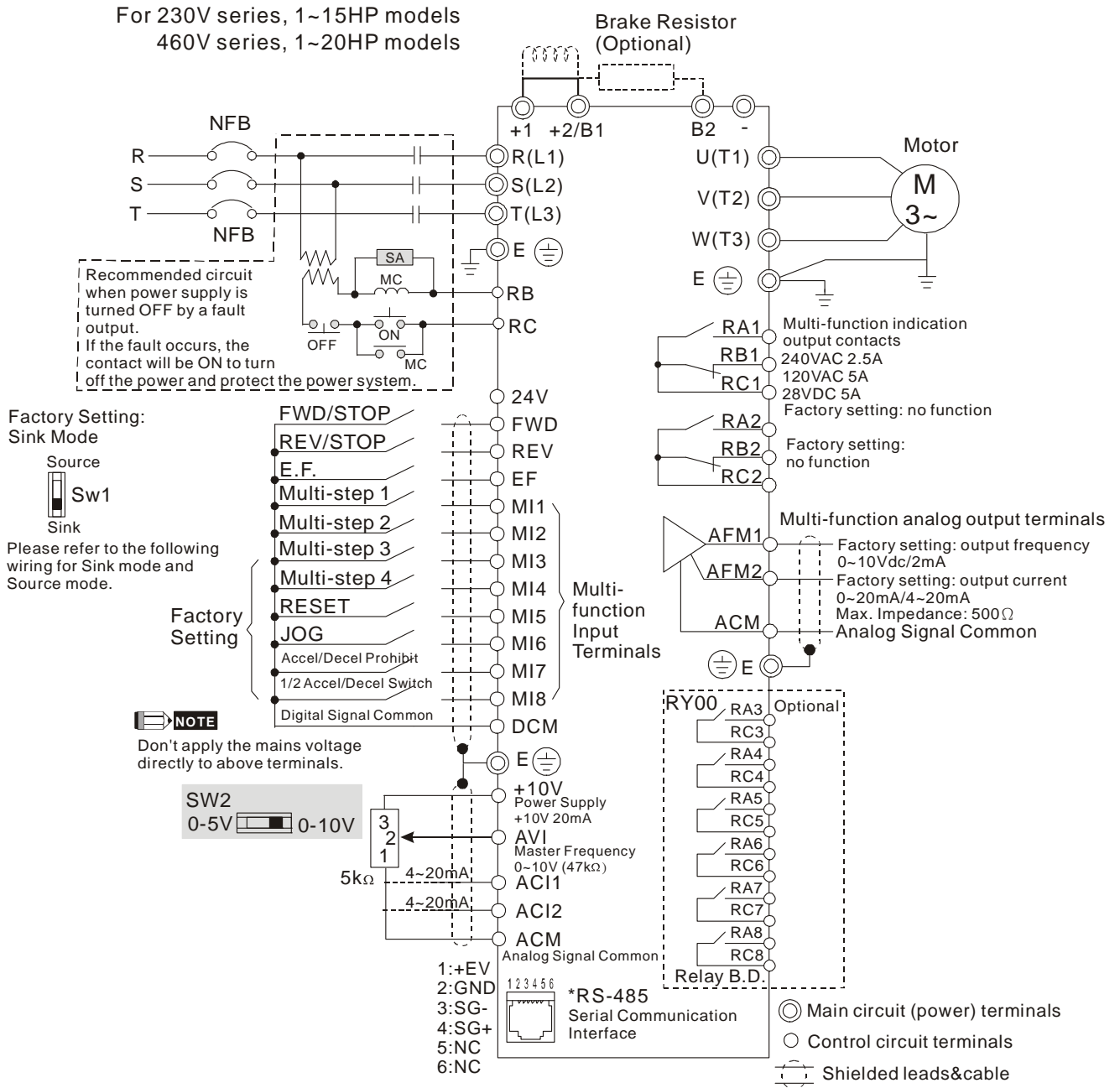

◆ VFD-F Wiring Diagram

For 230V series, 20HP and above models  
460V series, 25HP and above models

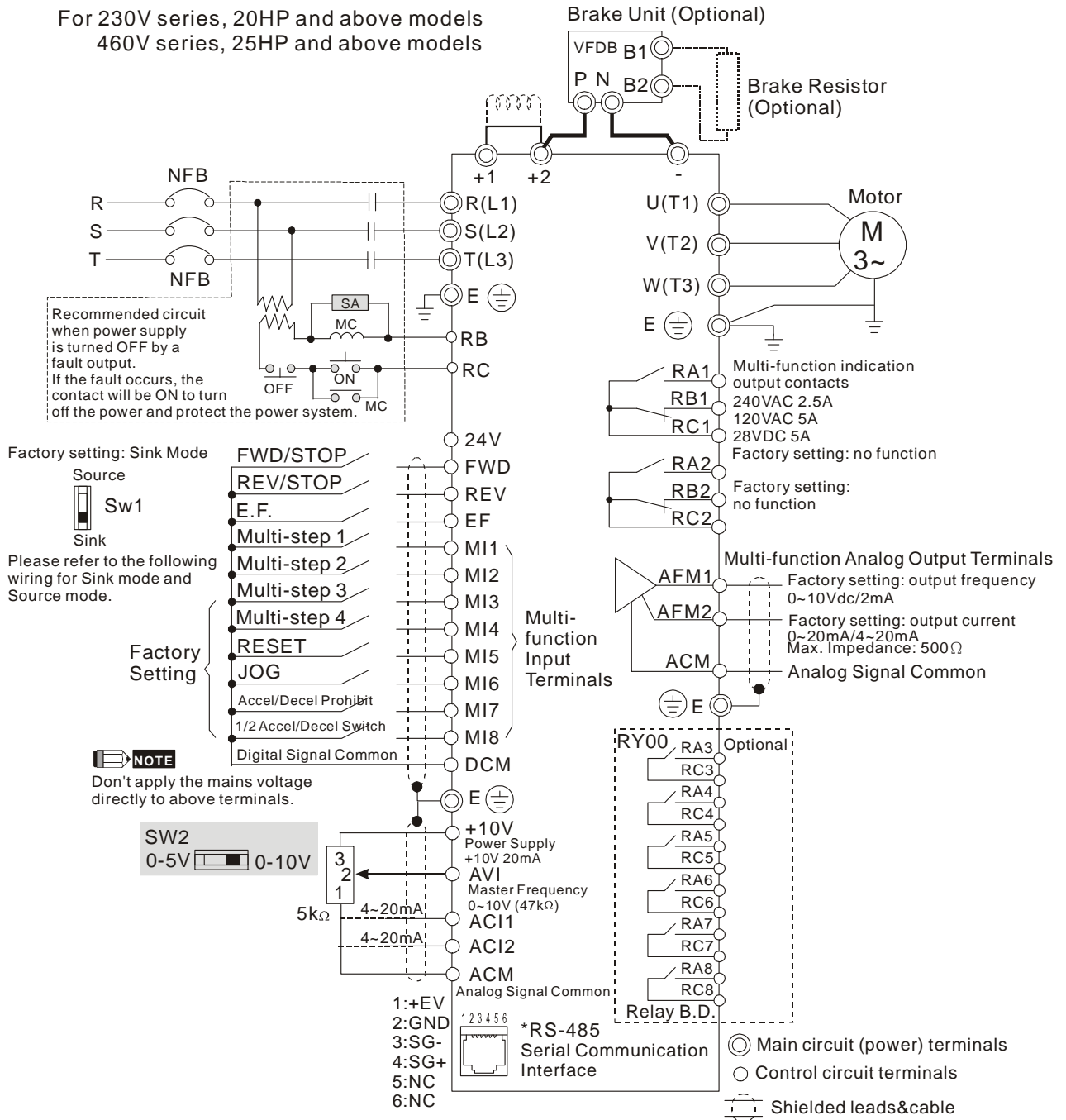

◆ **CP2000 Wiring Diagram:**

For 230V series, 0.5HP ~ 40HP models.

460V series, 0.5HP ~ 50 HP models

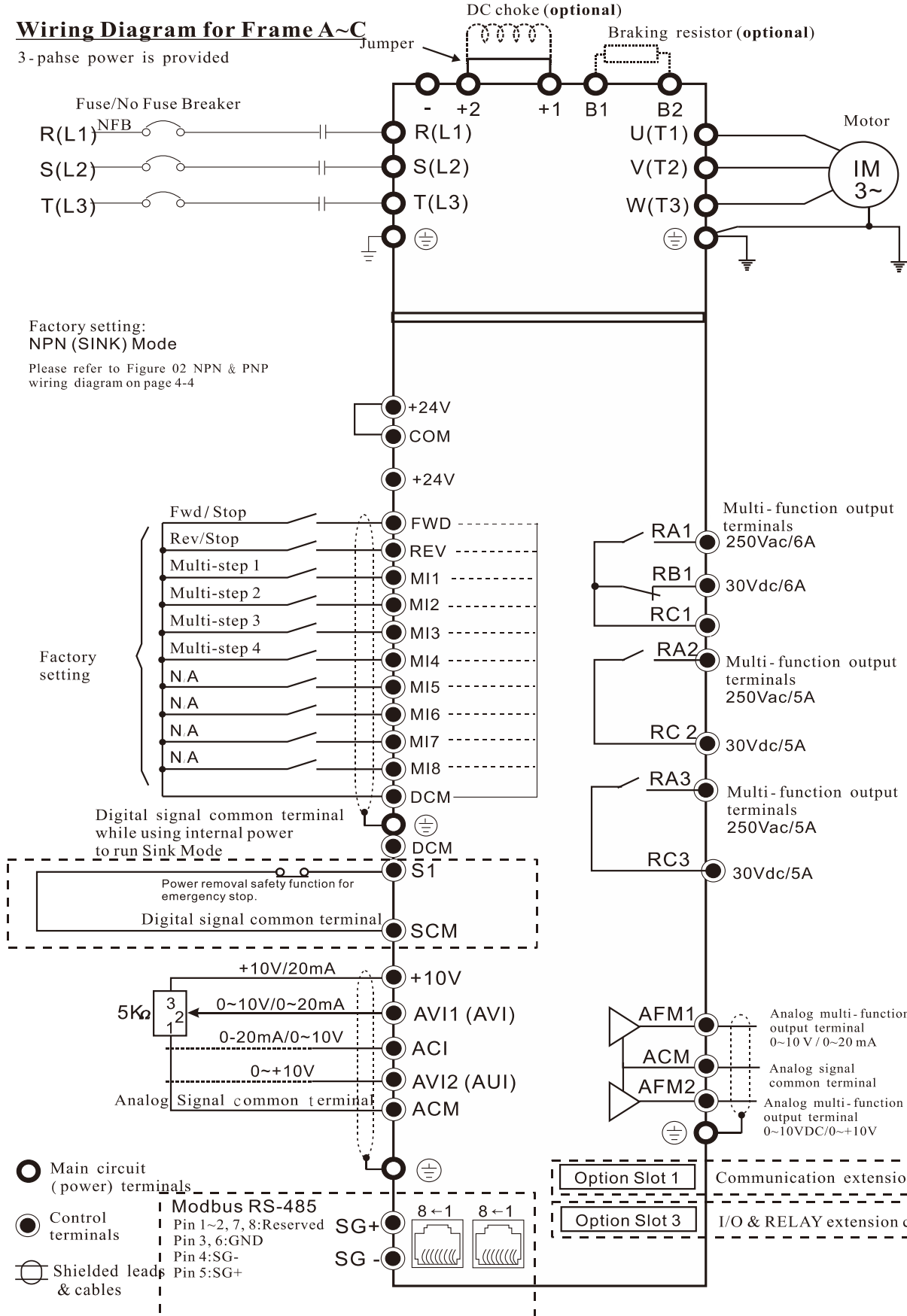

◆ **CP2000 Wiring Diagram:**

For 230V series, 40HP ~ 60HP models  
 460V series, 50HP ~125 HP models

Wiring Diagram for Frame D

3-phase power is provided

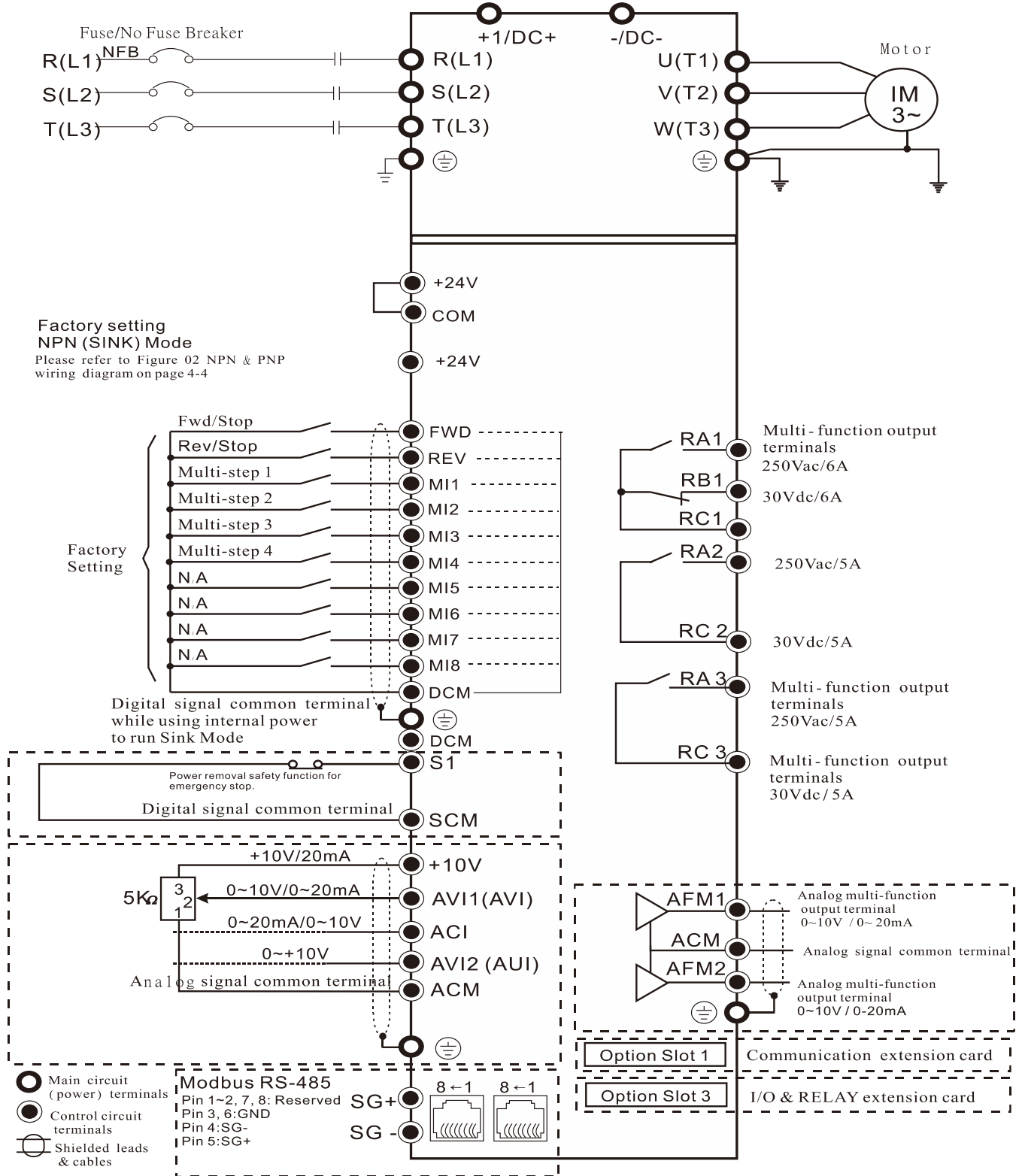

◆ **CP2000 Wiring Diagram:**

For 230V series, 60HP to 125HP models

460V series, 125HP to 536 HP models

**Wiring diagram for frame E and above**

3-phase power is provided

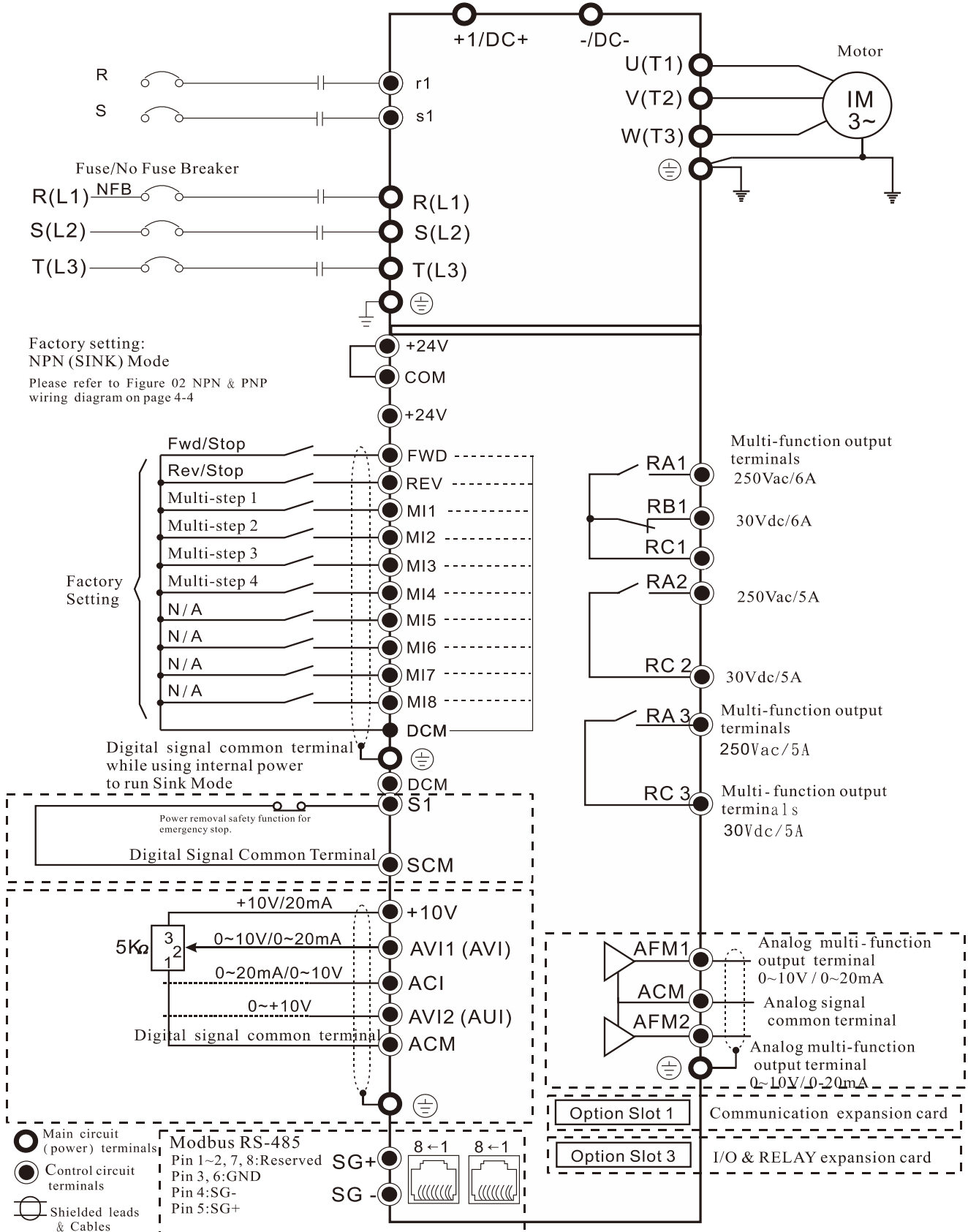

◆ CP2000 Internal Power Terminals for Frame G & Frame H

Input power terminals for frame G and H

Provides 3-phase power

Fuse or NFB (non-fuse breaker)

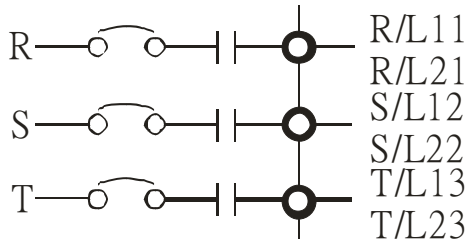

It provides 12-pulse power

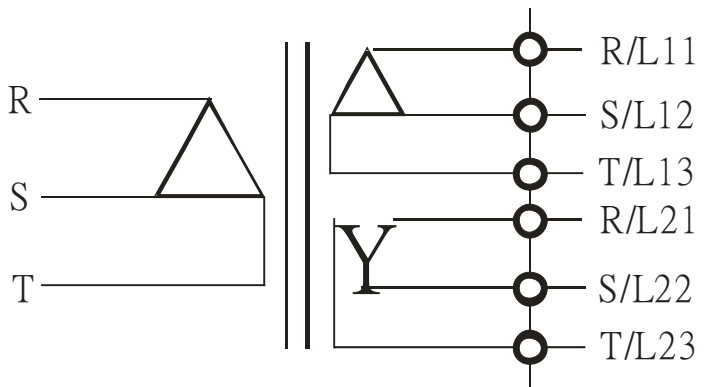

◆ CP2000 SINK (NPN) /SOURCE (PNP) Mode

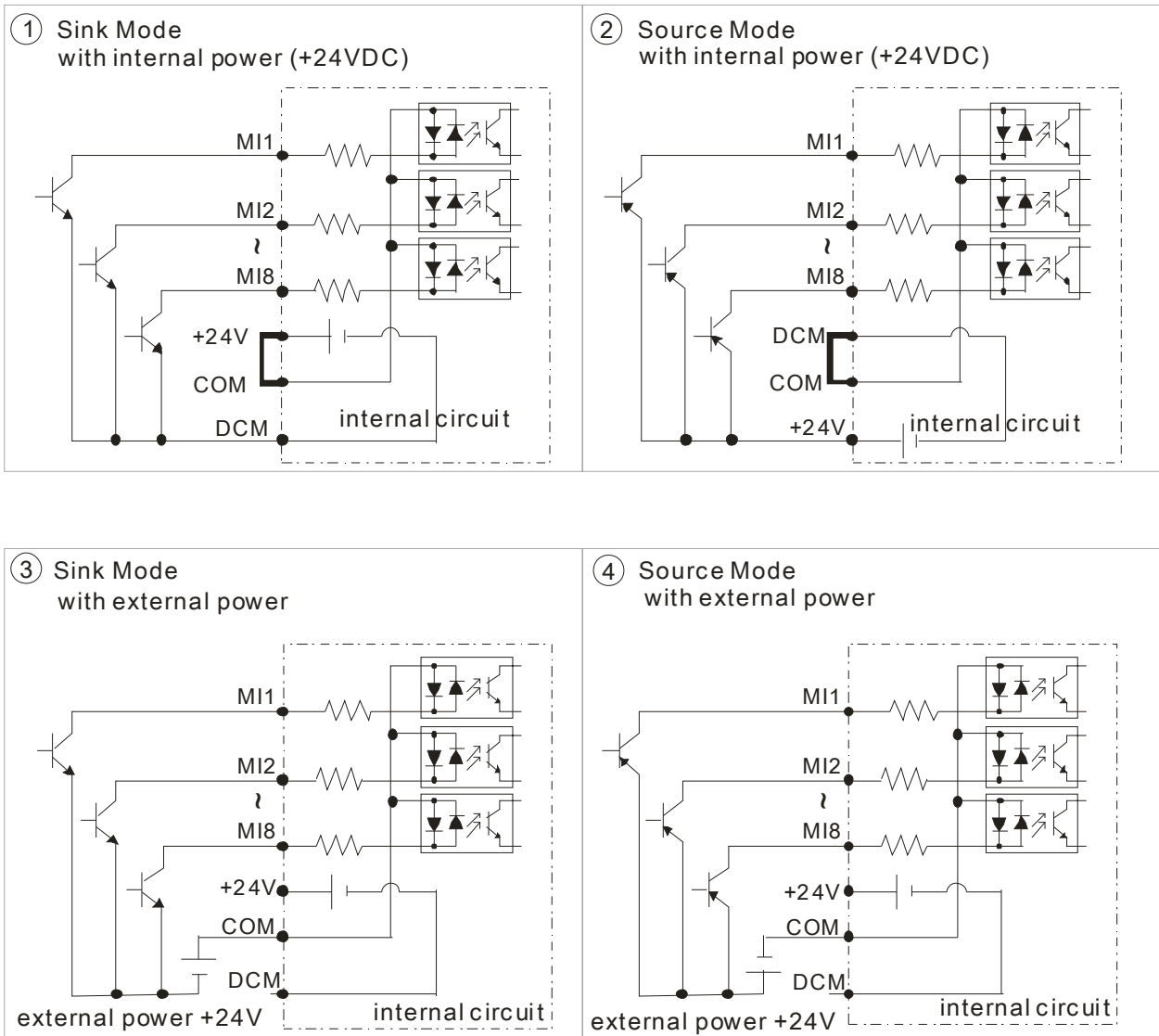

## 05 CP2000 Derating Charts

### ◆ Carrier Frequency Derating

▲ 460V:

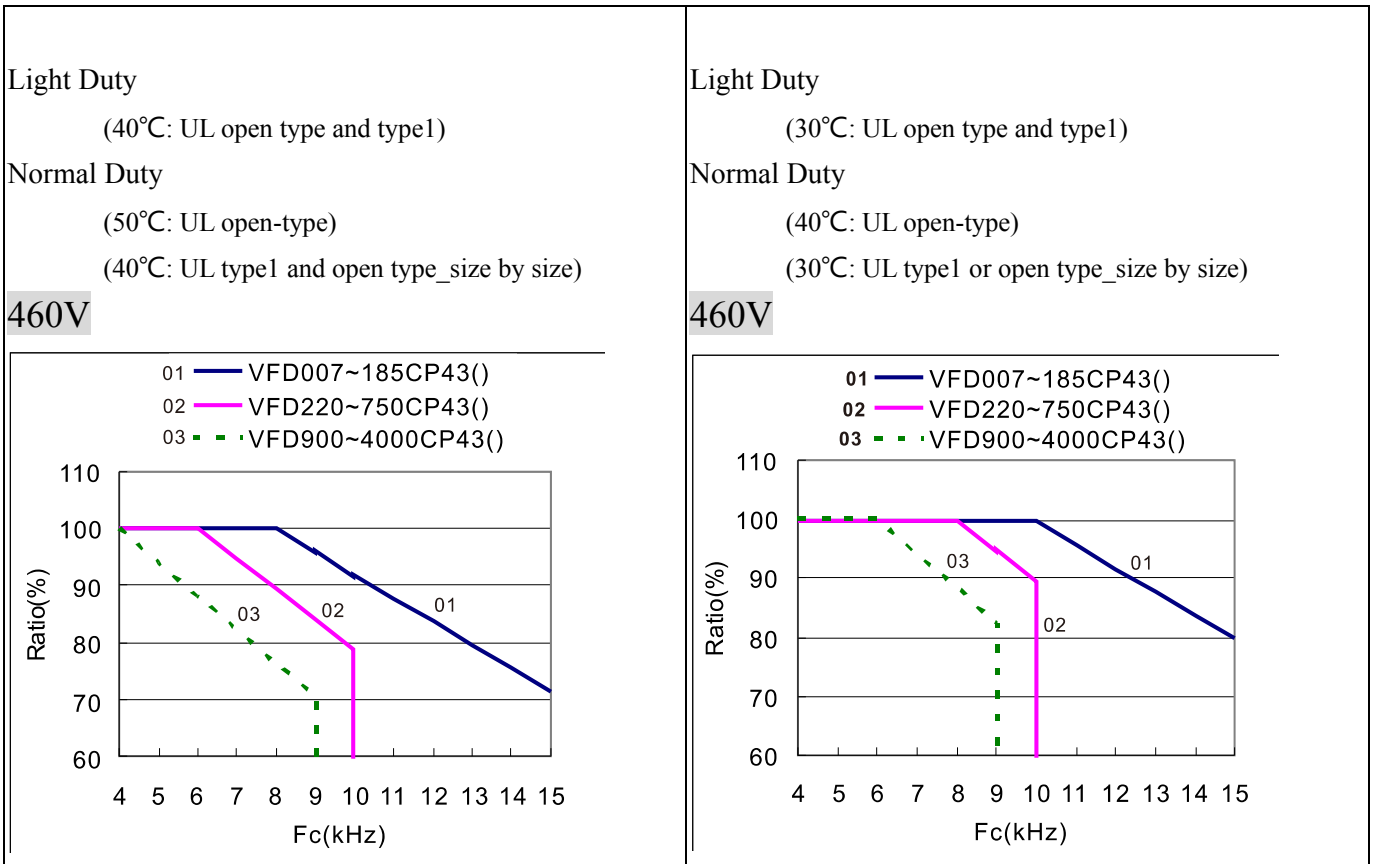

▲ 230V:

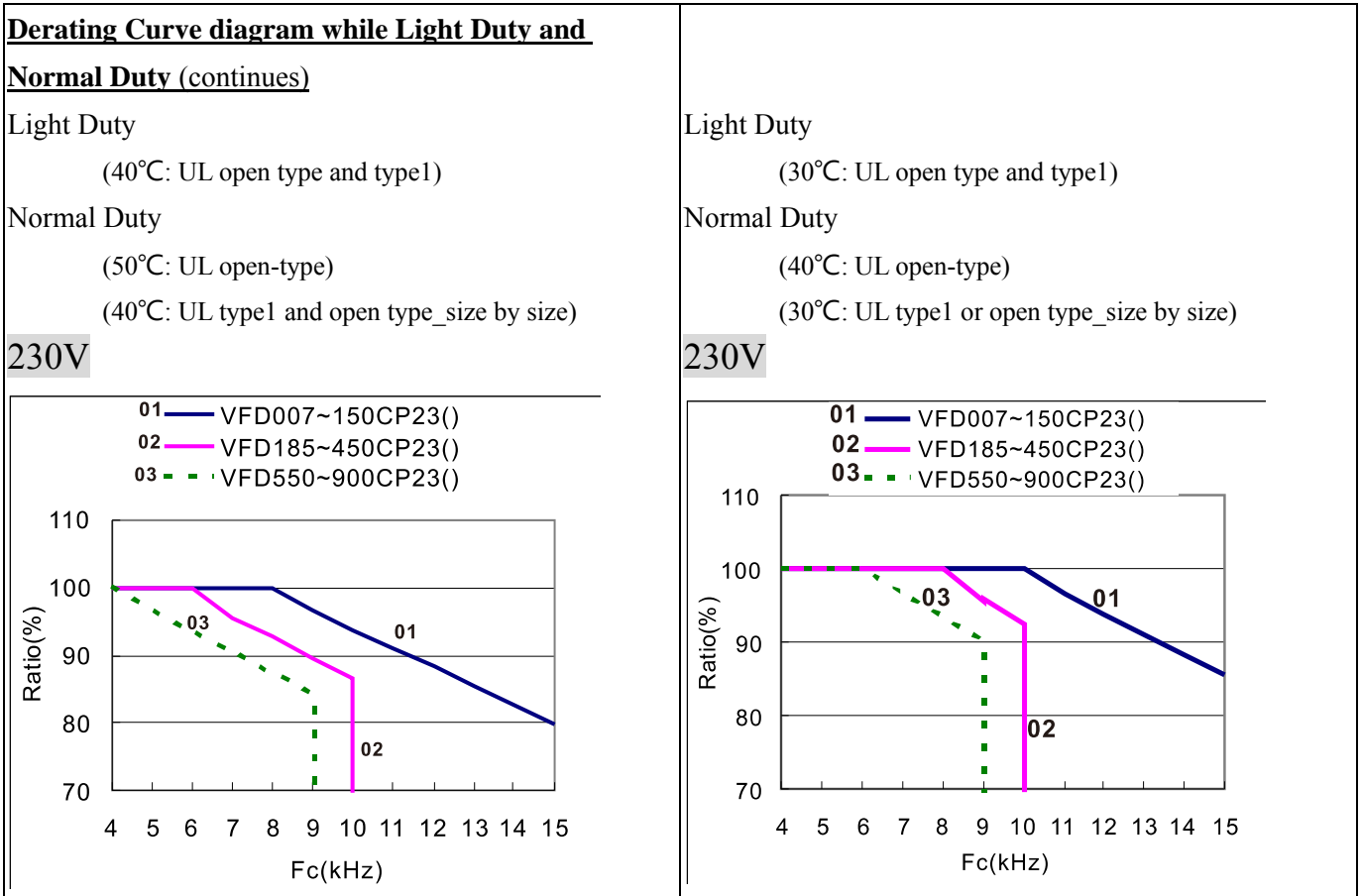



## ◆ Temperature Derating

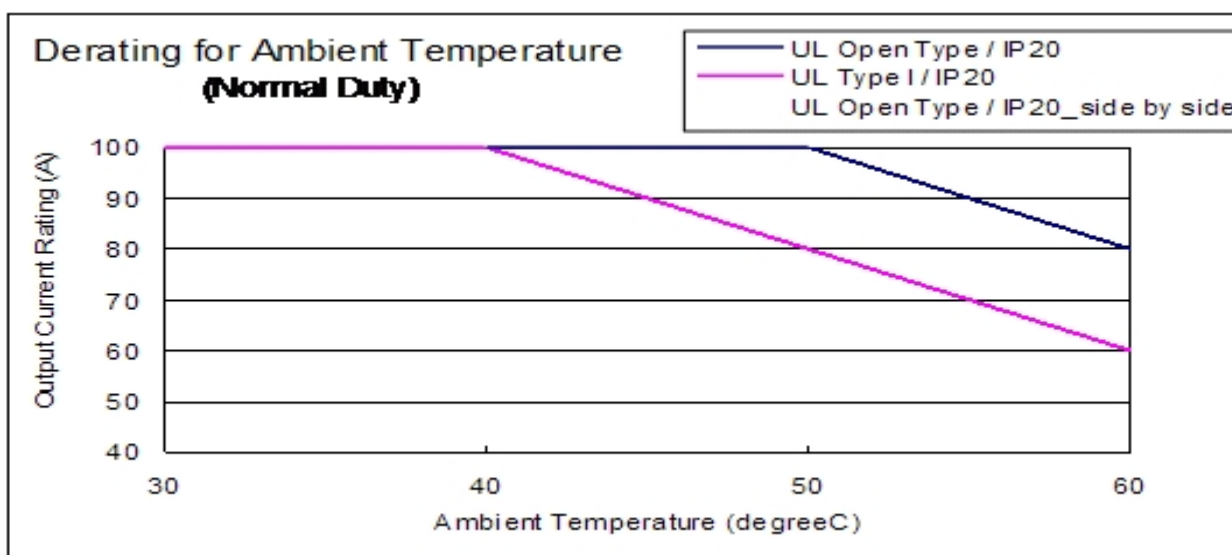
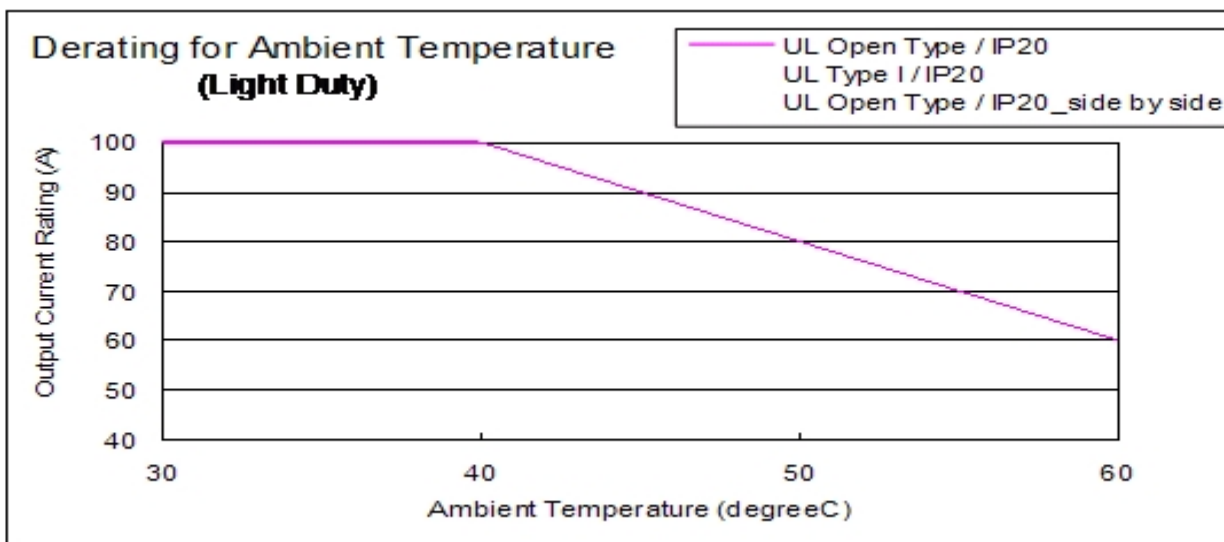

Operating Condition	Ambient Temperature Range & Limits
UL Type I / IP20 UL Open Type / IP20 (Light Duty)	When operating at the rated output current, the ambient temperature needs to be between -10 ~ +40°C. But when the temperature reaches 40°C, the rated output current needs to be decreased by 2% as the temperature increases by 1°C.. The maximum tolerable temperature is 60°C.
UL Type I / IP20 (Normal Duty)	When operating at the rated output current, the ambient temperature needs to be between -10 ~ +40°C. But when the temperature reaches 40°C, the rated output current needs to be decreased by 2% as the temperature increases by 1°C. The maximum tolerable temperature is 60°C.
UL Open Type / IP20 (Normal Duty)	When operating at the rated output current, the ambient temperature needs to be between -10 ~ +50°C. But when the temperature reaches 50°C, the rated output current needs to be decreased by 2% as the temperature increases by 1°C. The maximum tolerable temperature is 60°C.

◆ Altitude Derating

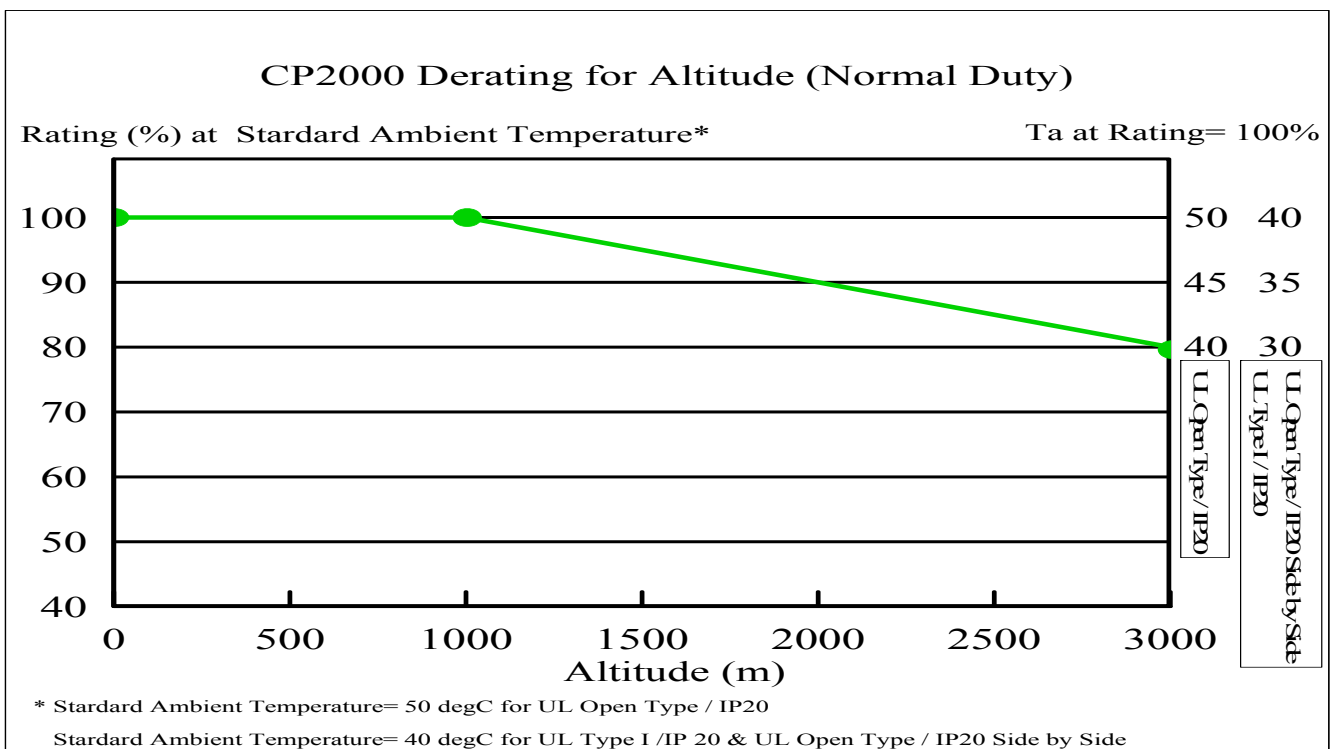
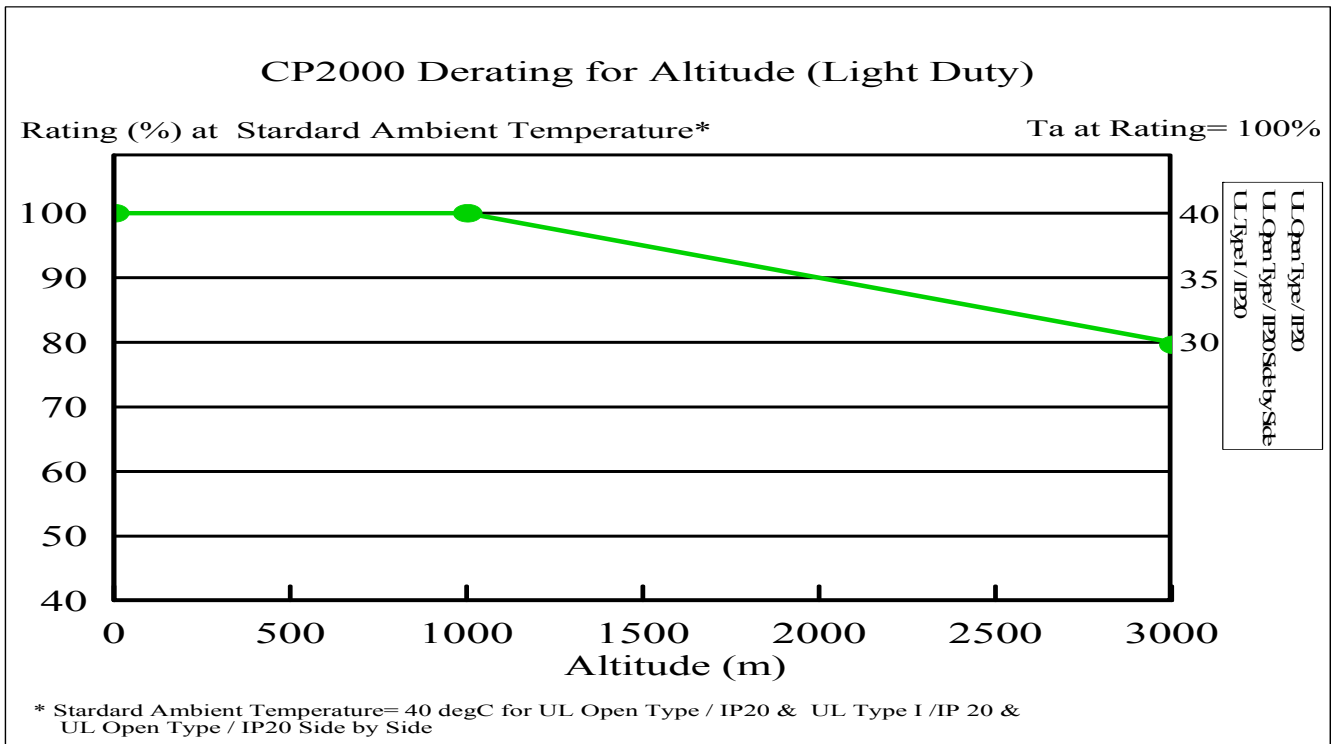

Operating Condition	Ambient Temperature Range & Limits
(Light Duty) (Normal Duty)	When operating at an altitude between 0~1000 m, follow the standard operating instructions. But when operating at an altitude between 1000 and 3000m, the rated output current needs to be decreased by 2% or by 0.5°C as the altitude increased by 100 meters. If the grounding system is Corner Grounded, the VFD can only be operated at an altitude under 2000m.

## 06 - CP2000 Optional Accessories

Category	Option	Model Number
Network Communication	DeviceNet	CMC-DN01
	EtherNet/IP	CMC-EIP01
	Modbus TCP/IP	CMC-MOD01
	Profibus DP	CMC-PD01
	CANopen	EMC-COP01
	CANopen Breakout Box	TAP-CN03
	CANopen Communication Cable 500mm	TAP-CB03
	CANopen Communication Cable 1000mm	TAP-CB04
Input/Output	Digital Input	EMC-D42A/EMC-D611A
	Digital Output	EMC-D42A/EMC-R6AA
Keypad	LCD Keypad	KPC-CC01
	LED Keypad	KPC-CE01
	Panel Mounitng Kit	(MKC-KPPK)
Flange Mounting Kit	Frame A	MKC-AFM/MKC-AFM1
	Frame B	MKC-BFM
	Frame C	MKC-CFM
USB/RS-485 Communication Interface	USB Gateway	IFD6530

## 07 - Comparison of Parameters

### ◆ VFD-F-Group00-User Parameter vs CP2000-Corresponding Parameters

VFD-F-Group00-User Parameter			CP2000-Corresponding Parameters		
Parameter	Function	Default	Parameter	Function	Default
	Setting			Setting	
00-00	Software Version	###	00-06	Software Version	###
	Read Only			Read Only	
00-01	01 AC Drive Status Indication 1	##	<b>N/A</b>		
	Read-only				
	00: No fault occurred				
	01: oc(over current)				
	02: ov(over voltage)				
	03: oH(over temperature)				
	04: oL(overload)				
	05: oL1(electronic thermal relay)				
	06: EF(external fault)				
	07: occ(AC drive IGBT fault)				
	08: CF3(CPU failure)				
	09: HPF(hardware protection failure)				
	10: ocA((over current during acceleration)				
	11: ocd((over current during deceleration)				
	12: ocn(over current during steady state operation)				
	13: GFF(ground fault))				
	14: Lv(under voltage or Low input voltage)				
	15: CF1(EEPROM input data is abnormal)				
	16: CF2(EEPROM output data is abnormal)				
	17: bb(base block)				
	18: oL2(motor over load 2)				
	19: Reserved				
	20: codE(software or password protection)				
	21: EF1(external emergency stop)				
	22: PHL(Phase Loss)				
	23: Lc (Low Current)				
	24: FbL(Feedback Loss)				
	25: Reserved				
	26:FAnP(Fan Power Fault )				

VFD-F-Group00-User Parameter			CP2000-Corresponding Parameters		
Parameter	Function	Default	Parameter	Function	Default
	Setting			Setting	
	27:FF1(Fan1 Fault) 28:FF2(Fan2 Fault) 29:FF3(Fan3 Fault) 30:FFo(All Fan Fault) 31:FF12(Fan1&2 Fault) 32:FF13(Fan1&3 Fault) 33:FF23(Fan2&3 Fault) 34:Fv(gate drive low volt protect) 41: HPP1 (GFF) 42: HPP2 (CC) 43: HPP3 (OC) 44: HPP4 (OV) 45: CF3.3 (U current sensor) 46: CF3.4 (V current sensor) 47: CF3.5 (W current sensor) 48: CF3.6 (DC Bus) 49: CF3.7 (Isum) 50: CF3.8 (OH)		N/A		
00-02	AC Drive Status Indication 2 (Read Only)	##			
	Bit 0-1 : 00 : RUN LED OFF · STOP LED ON 01 : RUN LED BLINK · STOP LED ON 10 : RUN LED ON · STOP LED BLINK 11 : RUN LED ON · STOP LED OFF Bit 2 : 1: JOG ON Bit 3-4 : 00 : REV LED OFF · FWD LED ON 01 : REV LED BLINK · FWD LED ON 10 : REV LED ON · FWD LED BLINK 11 : REV LED ON · FWD LED OFF Bit 5-7 : Reserved		N/A		
00-03	Frequency Setting (Read Only)	###.##	00-03	Start-up Display Selection	0
	Read Only			0 : F ( frequency command ) 1 : H ( output frequency ) 2 : U ( multi-fucntion display, see Pr.00-04 ) 3 : A ( output current )	

VFD-F-Group00-User Parameter			CP2000-Corresponding Parameters			
Parameter	Function	Default	Parameter	Function	Default	
	Setting			Setting		
00-04	Output Frequency (Read Only)	##.##	00-04	Content of Multi-function Display(User Defined)	0	
	Read Only			0: Display output current (A) 1: Display counter value (c) 2: Display actual output frequency (H.) 3: Display DC-BUS voltage (v) 4: Display output voltage (E) 5: Display output power angle (n) 6: Display output power in kW (P) 8: Display estimate output torque % (t) 10: Display PID feedback in % (b) 11: Display AVI in % (1.) 12: Display ACI in % (2.) 13: Display AUI in % (3.) 14: Display the temperature of IGBT in °C (i.) 15: Display the temperature of heat sink in °C (c.) 16: The status of digital input (ON/OFF) (i) 17: The status of digital output (ON/OFF) (o) 18: Multi-step speed (S) 19: The corresponding CPU pin status of digital input (d.) 20: The corresponding CPU pin status of digital output (O.) 25: Overload counting (0.00~100.00%) (h.) 26: Ground Fault GFF (Unit :%)( G.) 27: DC Bus voltage ripple (Unit: Vdc) (r.) 28: Display PLC data D1043 (C) 30: Display output of user defined (U) 31: H page x Pr.00-05 Display user Gain(K)		
00-05	Output Frequency (A)	##.#				
	Read Only					
00-06	DC-BUS Voltage (U)	##.##				
	Read Only					
00-07	Output Voltage (E)	##.##				
	Read Only					
00-08	Output Power Factor(n)	##				
	Read Only					
00-09	Output Power (P/q)KW	##				
	Read Only					
00-10	Feedback Signal Actual Value	##				
	Read Only					
00-11	Feedback Signal (%)	##				
	Read Only					
00-12	User Target Value (Low bit) uL 0-99.99	##.##				
	Read Only					

VFD-F-Group00-User Parameter			CP2000-Corresponding Parameters		
Parameter	Function	Default	Parameter	Function	Default
	Setting			Setting	
00-13	User Target Value (High bit) uH 0-9999	####	<b>N/A</b>		
	Read Only				
00-14	PLC time	##			
	Read Only				
00-15	Stall Torque Output(N.m)	##.#			
	Read Only				

## ◆ VFD-F-Group01-Basic Parameters vs CP2000-Corresponding Parameters

VFD-F-Group01-Basic Parameters			CP2000-Corresponding Parameters		
Parameter	Function	Default	Parameter	Function	Default
	Setting			Setting	
01-00	Maximum Output Frequency	60.00	01-00	Max. Operating Frequency (Hz)	60.00/ 50.00
	50.0 ~ 120.00 Hz			50.00~600.00Hz	
01-01	Maximum Voltage Frequency (Base Frequency)	60.00	01-01	Motor1: Max Output Frequency(Hz)	60.00/ 50.00
	0.10 ~ 120.00 Hz			0.00~600.00Hz	
01-02	Maximum Output Voltage	220.0 440.0/ 380.0	01-02	Motor1: Max Output Voltage (V)	220.0 400.0
	0.1 / 0.2V ~ 255.0 / 510.0V			230V series : 0.0V~255.0V 460V series : 0.0V~510.0V	
01-03	Mid-point Frequency	1.50	01-03	Mid-point Frequency 1 of Motor 1	3.0
	0.10 ~ 120.00 Hz			0.00~600.00Hz	
01-04	Mid-point Voltage	5.5 11.0	01-04	Mid-point Voltage 1 of Motor 1	110 220
	0.1 / 0.2V ~ 255.0 / 510.0V			230V series : 0.0V~240.0V 460V series : 0.0V~480.0V	
01-05	Minimum Output Frequency	1.50	01-07	Min. Output Frequency of Motor 1	0.00
	0.10 ~ 20.00 Hz			0.00~600.00Hz	
01-06	Minimum Output Voltage	5.5 11.0	01-08	Min. Output Voltage of Motor 1	0.0 0.0
	0.1 / 0.2V ~ 50.0 / 100.0V			230V series : 0.0V~240.0V 460V series : 0.0V~480.0V	
01-07	Upper Bound Frequency	60.00	01-10	Output Frequency Upper Limit	600.00
	0.00 ~ 120.00 Hz			0.00~600.00Hz	
01-08	Lower Bound Frequency	0.00	01-11	Output Frequency Lower Limit	0.00
	0.00 ~ 120.00 Hz			0.00~600.00Hz	
01-09	Acceleration Time 1	10.0/60.0	01-12	Accel. Time 1	10.00 10.0
	0.1 ~ 3600.0 Sec			Pr01-45=0 : 0.00~600.00 seconds Pr01-45=1 : 0.00~6000.0 seconds	
01-10	Deceleration Time 1	10.0/60.0	01-13	Decel. Time 1	10.00 10.0
	0.1 ~ 3600.0 Sec			Pr01-45=0 : 0.00~600.00 seconds; Pr01-45=1 : 0.00~6000.0 seconds	



VFD-F-Group01-Basic Parameters			CP2000-Corresponding Parameters		
Parameter	Function	Default	Parameter	Function	Default
	Setting			Setting	
01-11	Acceleration Time 2	10.0/60.0	01-14	Accel. Time 2	10.00 10.0
	0.1 ~ 3600.0 Sec			Pr01-45=0 : 0.00~600.00 seconds; Pr01-45=1 : 0.00~6000.0 seconds	
01-12	Deceleration Time 2	10.0/60.0	01-15	Decel. Time 2	10.00 10.0
	0.1 ~ 3600.0 Sec			Pr01-45=0 : 0.00~600.00 seconds Pr01-45=1 : 0.00~6000.0 seconds	
01-13	Acceleration Time 3	10.0/60.0	01-16	Accel. Time 3	10.00 10.0
	0.1 ~ 3600.0 Sec			Pr01-45=0 : 0.00~600.00 seconds; Pr01-45=1 : 0.00~6000.0 seconds	
01-14	Deceleration Time 3	10.0/60.0	01-17	Decel. Time 3	10.00 10.0
	0.1 ~ 3600.0 Sec			Pr01-45=0 : 0.00~600.00 seconds; Pr01-45=1 : 0.00~6000.0 seconds	
01-15	Acceleration Time 4	10.0/60.0	01-18	Accel. Time 4	10.00 10.0
	0.1 ~ 3600.0 Sec			Pr01-45=0 : 0.00~600.00 seconds; Pr01-45=1 : 0.00~6000.0 seconds	
01-16	Deceleration Time 4	10.0/60.0	01-19	Decel. Time 4	10.00 10.0
	0.1 ~ 3600.0 Sec			Pr01-45=0 : 0.00~600.00 seconds; Pr01-45=1 : 0.00~6000.0 seconds	
01-17	JOG Acceleration Time	10.0/60.0	01-20	JOG Acceleration Time	10.00 10.0
	0.1 ~ 3600.0 Sec			Pr01-45=0 : 0.00~600.00 seconds; Pr01-45=1 : 0.00~6000.0 seconds	
01-18	JOG Deceleration Time	10.0/60.0	01-21	JOG Deceleration Time	10.00 10.0
	0.1 ~ 3600.0 Sec			Pr01-45=0 : 0.00~600.00 seconds; Pr01-45=1 : 0.00~6000.0 seconds	
01-19	JOG Frequency	6.00	01-22	JOG Frequency	6.00
	0.0 Hz ~ 120.00 Hz			0.00~600.00Hz	

VFD-F-Group01-Basic Parameters			CP2000-Corresponding Parameters		
Parameter	Function	Default	Parameter	Function	Default
	Setting			Setting	
01-20	S Curve Delay Time in Accel	00	01-24	S-curve for Acceleration Departure Time 1	0.20seconds
	00 ~ 2.50sec		01-25	S-curve for Acceleration Arrival Time 2	0.2 seconds
01-21	S Curve Delay Time in Decel	00	01-26	S-curve for Deceleration Departure Time 1	0.20 seconds
	00 ~ 2.50sec		01-27	S-curve for Deceleration Arrival Time 2	0.2 seconds
				Pr01-45=0 : 0.00~25.00 seconds; Pr01-45=1 : 0.0~250.0 seconds	
01-22	Modulation Index	1.00	<b>N/A</b>		
	0.90 ~ 1.20				
01-23	Accel/Decel Time Unit(01-09~01-18)	01	01-45	Time Unit for Accel. /Decel. and S Curve	0
	00: Unit is 1 Sec 01: Unit is 0.1 Sec 02: Unit is 0.01 Sec			0 : Unit: 0.01 second 1 : Unit: 0.1 second	

### ◆ VFD-F-Group02-Operation Method Parameters vs CP2000-Corresponding Parameters

VFD-F-Group02-Operation Method Parameters			CP2000-Corresponding Parameters		
Parameter	Function	Default	Parameter	Function	Default
	Setting			Setting	
02-00	Source of Frequency Command	00	00-30	Source of Frequency Command ( HAND )	0
	00: via keypad 01: via analog input ACH2V 02: via analog input ACH2A 03: via analog input ACH3A 04: via RS485 serial communication 05: via External Reference			0: Digital keypad 1: RS-485 serial communication 2: External analog input (Pr.03-00) 3: External UP/DOWN terminal 6: CANopen communication card 8: Communication card (no CANopen card)	
02-01	Source of Operation Command	00	00-31	Source of Operation Command ( HAND )	0
	00: Controlled by the digital keypad 01: Controlled by the external terminals, keypad STOP enabled. 02: Controlled by the external terminals, keypad STOP disabled. 03: Controlled by the RS-485 communication interface, keypad STOP enabled. 04: Controlled by the RS-485 communication interface, keypad STOP disabled.			0: Digital keypad 1: External terminals. Keypad STOP disabled. 2: RS-485 serial communication. Keypad STOP disabled 3: CANopen communication card 5: Communication card (not include CANopen card)	
02-02	Stop Method	00	00-22	Stop Method	0
	00: Stop = ramp to stop, E.F. (External Fault) = coast to stop 01: Stop = coast to stop, E.F. = coast to stop 02: Stop = ramp to stop, E.F. = ramp to stop 03: Stop = coast to stop, E.F. = ramp to stop			0 : Ramp to stop 1 : Coast to stop	

VFD-F-Group02-Operation Method Parameters			CP2000-Corresponding Parameters			
Parameter	Function	Default	Parameter	Function	Default	
	Setting			Setting		
02-03	PWM Carrier Frequency Selections	##	00-17	Carrier Frequency		
	1K ~ 10KHz			2~15kHz	230V series	Light duty: 1~20hp
						Normal duty: 1~25hp
				460V series	Light duty: 1~25hp	
Normal duty: 0.5~20hp						
2~10kHz	230V series	Light duty: 25~60hp				
		Normal duty: 20~50hp				
460V series	Light duty: 30~100hp					
	Normal duty: 25~75hp					
2~9kHz	230V series	Light duty: 75~125hp				
		Normal duty: 60~100hp				
460V series	Light duty: 125~536hp					
	Normal duty: 100~475hp					
02-04	Forward/Reverse Enable	00	00-23	Motor Operating Direction Control		
	00: Forward/Reverse enabled 01: Reverse disabled 02: Forward disabled			0: Enable forward/reverse 1: Reverse disable 2: Forward disable		
02-05	2-wire/3-wire Operation Control Modes	00	02-00	2-wire/3-wire Operation Control		
	00: 2-wire (#1), FWD/STOP, REV/STOP			0: 2-wire mode, power on for operation control		
	01: 2-wire (#2), RUN/STOP, REV/FWD			1: 2-wire mode 2, power on for operation control		
02: 3-wire		2: 3-wire, power on for operation control				

VFD-F-Group02-Operation Method Parameters			CP2000-Corresponding Parameters		
Parameter	Function	Default	Parameter	Function	Default
	Setting			Setting	
02-06	Line Start Lockout	01	02-35	External Operation Control Selection after Reset or Activate	0
	00: Enabled 01: Disabled 02: If the command to run still remains after resetting, the inverter will continue to run.			0 : Disable 1 : Drive runs, if there is a Run command after reset.	
02-07	ACI ( 4~20mA ) Loss of ACI Signal	01	03-19	Loss of the ACI signal	0
	00: Decelerate to 0Hz 01: E.F. 02: Continue operation by the last frequency command 03: Use loss of ACI Signal Frequency of Pr02-16			0 : Disable 1 : Continue operating at the last frequency 2 : Decelerate to 0 Hz 3 : Stop immediately and display ACE	
02-08	Start-up Display Selection	00	00-03	Start-up Display Selection	0
	Bit0~1 00=F LED 01=H LED 10=u LED (special display)  Bit2 0=Fwd LED 1=Rev LED  Bit3~5 000=1st 7-seg 001=2nd 7-seg 010=3rd 7-seg 011=4th 7-seg 100=5th 7-seg  Bit6~7 Reserved			0 : F ( frequency command ) 1 : H ( output frequency ) 2 : U ( multi-function display, see Pr00-04 ) 3 : A (Output current )	

VFD-F-Group02-Operation Method Parameters			CP2000-Corresponding Parameters		
Parameter	Function	Default	Parameter	Function	Default
	Setting			Setting	
02-09	Special Display	00	00-04	Content of Multi-function display (User Defined)	3
	00: A displays output current of AC drive 01: U displays DC-Bus voltage of AC drive 02: E displays RMS of output voltage 03: P displays feedback signal 04: PLC display auto procedure state 05: T displays heat sink's temperature 06: The keypad's screen displays both target value and feedback value controlled by PID. (Proportional-Integral-Derivative controller (PID controller))			1: Display counter value (c) 2: Display actual output frequency (H.) 3: Display DC-BUS voltage (v) 4: Display output voltage (E) 5: Display output power angle (n) 6: Display output power in kW (P) 8: Display estimate output torque % (t) 10: Display PID feedback in % (b) 11: Display AVI in % (1.) 12: Display ACI in % (2.) 13: Display AUI in % (3.) 14: Display the temperature of IGBT in °C (i.) 15: Display the temperature of heat sink in °C (c.) 16: The status of digital input (ON/OFF) (i) 17: The status of digital output (ON/OFF) (o) 18: Multi-step speed (S) 19: The corresponding CPU pin status of digital input (d.) 20 : The corresponding CPU pin status of digital output (O. ) 25 : Overload counting (0.00~100.00%) (h.) 26 : Ground Fault GFF (Unit :%)( G.) 27: DC Bus voltage ripple (Unit: Vdc) (r.) 28: Display PLC data D1043 (C) 30: Display output of user defined (U) 31: H page x Pr.00-05 Display user Gain(K)	
02-10	User Defined Coefficient	1.00	00-05	Coefficient Gain in Actual Output Frequency	0
	0.01 ~ 160.00			0~160.00	
02-11	Flying Start	00	07-12	Speed Search while Start-up	0
	00:Disable 01: Enable (DC brake disabled)			0: Disable 1: Speed search starting from maximum output frequency 2: Speed search starting from start-up motor frequency 3: Speed search starting from minimum output frequency	
02-12	Flying Start Frequency	00			
	00: Begin search from Master Frequency Command 01: Begin search from Maximum Frequency (Pr.01-00)				

VFD-F-Group02-Operation Method Parameters			CP2000-Corresponding Parameters		
Parameter	Function	Default	Parameter	Function	Default
	Setting			Setting	
02-13	Master Frequency Memory Setting	01	<b>N/A</b>		
	00: Do not remember the last known frequency 01: Remember the last known frequency				
02-14	Source of Second Frequency Command	00	00-20	Source of AUTO Frequency Command (AUTO)	0
	00 : Master Frequency Setting is controlled by the digital keypad. 01 : Master frequency is controlled by an external terminal via analog input. AVI: DC 0~+10V. 02 : Master frequency is controlled by an external terminal via analog input. ACI1: DC 4~ 20mA. 03 : Master frequency is controlled by an external terminal via analog input. ACI2: DC 4~ 20mA 04 : Master frequency is handled via RS485 serial Communication. (RJ-11). 05 : External Reference Master frequency via External Reference.			0 : Digital keypad  1 : RS-485 serial communication  2 : External Analog Input (Pr03-00 )  3 : External UP/DOWN Terminal  6: CANopen communication card  8: Communication card (no CANopen card)	
02-15	Source of Second Operation Command	00	00-21	Source pf AUTO Functioning Command ( AUTO )	0
	00: Controlled by the digital keypad 01: Controlled by the external terminals, keypad STOP enabled. 02: Controlled by the external terminals, keypad STOP disabled. 03: Controlled by the RS-485 communication interface, keypad STOP enabled. 04: Controlled by the RS-485 communication interface, keypad STOP			0: Digital keypad 1: External analog input (Pr.03-00)  2: RS-485 serial communication  3: External UP/DOWN terminal  5: Communication card ( not included CANopen card)	
02-16	Loss of ACI Signal	0.00	<b>N/A</b>		
	0.00-Highest operational frequency				

◆ VFD-F-Group03-Output Function Parameters vs CP2000-Corresponding Parameters

VFD-F-Group03-Output Function Parameters			CP2000-Corresponding Parameters		
Parameter	Function	Default	Parameter	Function	Default
	Setting			Setting	
03-00	Multi-function Output terminal 1 (Relay 1)	0	02-13	RLY1: Multi Output Terminal	11
03-01	Multi-function Output terminal 2 (Relay 2)	0	02-14	RLY2: Multi Output Terminal	1
03-02	Multi-function Output terminal 3 (Relay 3)	0	02-15	RLY3: Multi Output Terminal	0
03-03	Multi-function Output terminal 4 (Relay 4)	0	02-36	Expansion Card Output Terminal (MO3)	0
03-04	Multi-function Output terminal 5 (Relay 5)	0	02-37	Expansion Card Output Terminal (MO4)	0
03-05	Multi-function Output terminal 6 (Relay 6)	0	02-38	Expansion Card Output Terminal (MO5)	0
03-06	Multi-function Output terminal 7 (Relay 7)	0	02-39	Output terminal of the I/O extension card(MO6)	0
03-07	Multi-function Output terminal 8 (Relay 8)	0	02-40	Output terminal of the I/O extension card(MO7)	0
	No function		02-41	Output terminal of the I/O extension card (MO8)	0
	01:Motor NO.1		02-42	Output terminal of the I/O extension card(MO9)	0
	02:Motor NO.2		02-43	Output terminal of the I/O extension card(MO10)	0
	03:Motor NO.3		02-44	Output terminal of the I/O extension card(MO11)	0
	04:Motor NO.4		02-45	Output terminal of the I/O extension card(MO12)	0
	05:Motor NO.5		02-46	Output terminal of the I/O extension card(MO13)	0
	06:Motor NO.6			0: Disable	
	07:Motor NO.7			1: Operation Indication	
	08:Motor NO.8			2: Operation speed attained	
	09:Auxiliary 1 output				
	10:Auxiliary 2 output			4: Desired frequency attained 2 (Pr.02-24)	
	11:Auxiliary 3 output			5: Zero speed (Frequency command)	
	12:Auxiliary 4 output			6: Zero speed, include STOP(Frequency command)	
	13:Auxiliary 5 output			7: Over torque 1	
	14:Auxiliary 6 output			8: Over torque 2	
	15:Auxiliary 7 output			9: Drive is ready	
	16:Indication during operation			10: Low voltage warning ( LV ) (Pr.06-00)	
	17:Master frequency attained			11: Malfunction indication	
	18:Zero Speed (including shutdown)			12: Mechanical brake release(Pr.02-32)	
	19:Over-torque			13: Overhat warning (Pr06-15)	



VFD-F-Group03-Output Function Parameters			CP2000-Corresponding Parameters		
Parameter	Function	Default	Parameter	Function	Default
	Setting			Setting	
	20:External Fault			14: Software brake signal indication(Pr.07-00)	
	21:Low voltage detection			15: PID feedback error	
	22:Operation Mode indication			16: Slip error (oSL)	
	23:Fault Indication			17: Terminal count value attained, does not return to 0	
	24:Master Frequency Attained 1			18: Preliminary count value attained, returns to 0 (Pr02-19)	
	25:Master Frequency Attained 2			19: Base mask	
	26:Over Temperature indication			20: Warning Output	
	27:Drive Ready			21: Over voltage warning	
	28:External Emergency Stop (EF1)			22: Over-current stall prevention warning	
	29:Software brake output			23: Over-voltage stall prevention warning	
	30:OL or OL1 overload warning			24: Operation mode indication	
	31: Dwell indication (sleep)			25: Forward command	
	32:Low current indication			26: Reverse command	
	33:PID Feedback error indication			27: Output when current $\geq$ Pr.02-33 ( $\geq$ 02-33)	
	34:PLC Program Running			28: Output when current $\leq$ Pr.02-33 ( $\leq$ 02-33)	
	35:PLC Program Step Completed			29: Output when frequency $\geq$ Pr.02-34 ( $\geq$ 02-34)	
	36:PLC Program Completed			30: Output when frequency $\leq$ Pr.02-34 ( $\leq$ 02-34)	
	37:PLC Operation Paused			31: Y-connection for the motor coil	
	38: Loss of an ACI signal Indication			32: $\Delta$ -connection for the motor coil	
	39:HOA-Hand mode indication			33: Zero speed (actual output frequency)	
	40:HOA-Off mode indication			34: Zero speed include stop(actual output frequency)	
	41:HOA-Auto mode indication			35: Error output selection 1(Pr.06-23)	
	42:Fire mode indication			36: Error output selection 2(Pr.06-24)	
	43:Bypass fire mode indication			37: Error output selection 3(Pr.06-25)	
				38: Error output selection 4(Pr.06-26)	
				40: Speed attained (including Stop)	
				44: Low current output	
				45: UVW Magnetic Contactor enabled	
				47: Brake output closed	
				50: Output for CANopen control	

VFD-F-Group03-Output Function Parameters			CP2000-Corresponding Parameters		
Parameter	Function	Default	Parameter	Function	Default
	Setting			Setting	
	N/A			51: Output for RS485 52: Output for communication 54: Bypass fire mode indication 55: Motor #1 Output 56: Motor #2 Output 57: Motor #3 Output 58: Motor#4 Output 59: Motor#5 Output 60: Motor #6 Output 61: Motor#7 Output 62: Motor#8 Output	
03-08	Master Frequency Attained 1	0.00	02-22	Desired Frequency Attained 1	60.00/ 50.00
	0.00 ~ 120.00 Hz			0.00 ~ 600.00Hz	
03-09	Master Frequency Attained 2	0.00	02-24	Desired Frequency Attained 2	60.00/ 50.00
	0.00 ~ 120.00 Hz			0.00 ~ 600.00Hz	
03-10	Analog Output 1 AFM1 0~10V	00	03-20	Multi-function Output 1 (AFM1)	0
03-11	Analog Output 2 AFM2 0/4~ 20mA	01	03-23	Multi-function Output 2 ( AFM2 )	0
	00: Output frequency 01: Output current 02: Output voltage 03: Frequency command 04: Power factor loading			0: Output frequency (Hz) 1: Frequency command (Hz) 2: Motor speed (Hz) 3: Output current (rms) 4: Output voltage 5: DC Bus voltage 6: Power factor 7: Power 9 : AVI % 10 : ACI % 11 : AUI % 20: CANopen analog output 21: RS485 analog output 22: Communication card analog output 23: Constant voltage output	

VFD-F-Group03-Output Function Parameters			CP2000-Corresponding Parameters		
Parameter	Function	Default	Parameter	Function	Default
	Setting			Setting	
03-12	Analog Output Gain 1	100	03-21	Gain for Analog Output 1 (AFM1)	100
	01 ~ 200%			0~500.0%	
03-13	Analog Output Gain 2	100	03-24	Gain for Analog Output 2 (AFM2)	100
	01~200%			0~500.0%	
03-14	Analog Output 2 Selection	01	03-31	AFM2 0-20mA Output Selection	0
	00: 0 ~ 20mA			0: 0~20mA	
	01: 4 ~ 20mA			1: 4~20mA	
03-15	DC Fan Control	4	07-19	Fan Cooling Control	0
	00:Fan runs on power up.			0: Fan always ON	
	01:Fan stops 1 minute after a STOP command			1: 1 minute after the AC motor drive stops, fan will be OFF	
	02:Fan begins upon RUN. Fan stops at STOP			2: When the AC motor drive runs, the fan is ON. When the AC motor drive stops, the fan is OFF	
	03:Fan is controlled by temperature. Approximately at 60°C temperature will start the fan.			3: Fan turns ON when the preliminary heat sink's temperature reached around 60°C (140°F).	
	04:Unusual Fan status warning, inverter continues to run. (Above 150hp)			4: Fan always OFF.	

◆ VFD-F-Group04-Input Function Parameters vs CP2000-Corresponding Parameters

VFD-F-Group04-Input Function Parameters			CP2000-Corresponding Parameters		
Parameter	Function	Default	Parameter	Function	Default
	Setting			Setting	
04-00	Multi-function Input terminal 1	01	02-01	Multi-function Input Command 1 (MI1)	1
04-01	Multi-function Input terminal 2	02	02-02	Multi-function Input Command 2 (MI2)	2
04-02	Multi-function Input terminal 3	03	02-03	Multi-function Input Command 3 (MI3)	3
04-03	Multi-function Input terminal 4	04	02-04	Multi-function Input Command 4 (MI4)	4
04-04	Multi-function Input terminal 5	05	02-05	Multi-function Input Command 5 (MI5)	0
04-05	Multi-function Input terminal 6	07	02-06	Multi-function Input Command 6 (MI6)	0
04-06	Multi-function Input terminal 7	08	02-07	Multi-function Input Command 7 (MI7)	0
04-07	Multi-function Input terminal 8	09	02-08	Multi-function Input Command 8 (MI8)	0
	No function		02-26	Input terminal of I/O extension card (MI9)	0
	01:Multi-Speed terminal 1		02-27	Input terminal of I/O extension card (MI10)	0
	02:Multi-Speed terminal 2		02-28	Input terminal of I/O extension card (MI11)	0
	03:Multi-Speed terminal 3		02-29	Input terminal of I/O extension card (MI12)	0
	04:Multi-Speed terminal 4		02-30	Input terminal of I/O extension card (MI13)	0
	05:Reset ( NO )		02-31	Input terminal of I/O extension card (MI14)	0
	06:Reset ( NC )			0 : Disable	
	07: Jog Operation(JOG)			1: Multi-step speed command 1/multi-step position command 1	
	08:Accel/Decel disable			2: Multi-step speed command 2/multi-step position command 2	
	09:Accel/Decel 1, 2 selection			3: Multi-step speed command 3/multi-step position command 3	
	10:Accel/Decel 3, 4 selection			4: Multi-step speed command 3/multi-step position command 4	
	11:B.B ( NO ) input			5: Reset	
	12:B.B ( NC ) input			6: JOG command(By KPC-CC01 or external ctrl)	
	13:Up Command			7: Acceleration/deceleration speed inhibit	
	14:Down Command			8: The 1st, 2nd acceleration/deceleration time selection	
	15:Emergency Stop EF1(NO)			9: The 3rd, 4th acceleration/deceleration time selection	
	16:Emergency Stop EF1(NC)			10: EF Input (Pr.07-20)	
	17:ACH1(open) · ACH2(close)			11: B.B input from external (Base Block)	

VFD-F-Group04-Input Function Parameters			CP2000-Corresponding Parameters		
Parameter	Function	Default	Parameter	Function	Default
	Setting			Setting	
	18:KEYPAD(open) · EXT(close)			12: Output stop	
	19:PID disable			13: Cancel the setting of optimal accel. /decel. Time	
	20:Auxiliary 1 input			14: Switch between motor 1 and motor 2	
	21:Auxiliary 2 input			15: Operation speed command from AVI1	
	22:Auxiliary 3 input			16: Operation speed command from ACI	
	23:Auxiliary 4input			17: Operation speed command from AVI2	
	24:Auxiliary 5 input			18: Emergency stop (Pr.07-20)	
	25:Auxiliary 6 input			19: Digital up command	
	26:Auxiliary 1 input			20: Digital down command	
	27:Motor NO.1 disable			21: PID function disabled	
	28:Motor NO.2 disable			22: Clear counter	
	29:Motor NO.3 disable			23: Input the counter value (MI6)	
	30:Motor NO.4 disable			24 : FWD JOG command	
	31:All motor outputs disable			25 : REV JOG command	
	32:Run PLC Program			28: Emergency stop (EF1)	
	33:Pause PLC Program			29: Signal confirmation for Y-connection	
	34:Enable source of the second frequency			30: Signal confirmation for -connection	
	35:Enable the source of second operation command			38: Disable EEPROM write function	
	36: Motor NO. 5 disabled			40: Force coast to stop	
	37: Motor NO. 6 disabled			41: HAND switch	
	38: Motor NO. 7 disabled			42: AUTO switch	
	39: Motor NO. 8 disabled			44~47 : Reserved	
	40:HOA Hand moe indication			49: Drive enable	
	41:HOA Auto mode indication			51: Selection for PLC mode bit0	
	42:Enable Fire Mode(NO)			52: Selection for PLC mode bit1	
	43:Enable Fire Mode(NC)			53: Trigger CANopen quick stop	
				54: UVW Magnetic Contactor On/Off	
				55: Brake Released Signal	
				56: Max. Reverse Disabled	
				57: Max Forward Disabled	

VFD-F-Group04-Input Function Parameters			CP2000-Corresponding Parameters		
Parameter	Function	Default	Parameter	Function	Default
	Setting			Setting	
	N/A			58: Enable fire mode (with RUN Command) 59: Enable fire mode (without RUN Command) 60: All motors disabled 61: Motor#1 disabled 62: Motor#2 disabled 63: Motor#3 disabled 64: Motor#4 disabled 65: Motor #5 disabled 66: Motor#6 disabled 67: Motor#7 disabled 68: Motor#8 disabled	
04-08	Digital Input Terminal Response Time	01	02-11	Multi-function Input Response Time	0.005
	02~20			0.000~30.000seconds	
04-09	ACH1(V) Minimum scaling	0.0	03-50	AI Calculation Mode	0
04-10	ACH1(V) Maximum scaling	10.0	03-51	AVI1 point 1 - voltage	0.00
04-11	ACH1(V) Minimum scaling percentage	0.00	03-52	AVI1 point 1 - percentage	0
04-12	ACH1(V) Maximum scaling percentage	100.00	03-53	AVI1 point 2 - voltage	5.00
04-13	ACH2(A) Minimum scaling	4.0	03-54	AVI1 point 2 - percentage	50
04-14	ACH2(A) Maximum scaling	20.0	03-55	AVI1 point 3 - voltage	10.00
04-15	ACH2(A) Minimum percentage	0.00	03-56	AVI1 point 3 - percentage	100
04-16	ACH2(A) Maximum percentage	100.00	03-57	ACI point 1 - voltage	4.00
04-17	ACH3(A) Minimum scaling	4.0	03-58	ACI point 1 - percentage	0
04-18	ACH3(A) Maximum scaling	20.0	03-59	ACI point 2 - voltage	12.00
04-19	ACH3(A) Minimum percentage	0.00	03-60	ACI point 2 - percentage	50
04-20	ACH3(A) Maximum percentage	100.00	03-61	ACI point 3 - voltage	20.00
	01 ~ 20		03-62	ACI point 3 - percentage	100
	0.0 to 10.0V		03-63	AVI2 point 1 - voltage	0.00
	0.0 to 10.0V		03-64	AVI2 point 1 - percentage	0
	0.00 to 100.00%		03-65	AVI2 point 2 - voltage	5.00
	0.00 to 100.00%		03-66	AVI2 point 2 - percentage	50
	0.0 to 20.0mA		03-67	AVI2 point 3 - voltage	10.00
	0.0 to 20.0mA		03-68	AVI2 point 3 - percentage	100

VFD-F-Group04-Input Function Parameters			CP2000-Corresponding Parameters		
Parameter	Function	Default	Parameter	Function	Default
	Setting			Setting	
	0.00 to 100.00%			0~7	
	0.00 to 100.00%			0~10.00 / 0~20.00	
	0.0 to 20.0mA			0~100%	
	0.0 to 20.0mA			0~10.00 / 0~20.00	
	0.00 to 100.00%			0~100%	
	0.00 to 100.00%			0~10.00 / 0~20.00	
				0~100%	
				0~10.00 / 0~20.00	
				0~100%	
				0~10.00 / 0~20.00	
				0~100%	
				0~10.00V	
				0~100%	
				0~10.00V	
				0~100%	
				0~10.00V	
				0~100%	
				0~10.00V	
				0~100%	
04-21	Analog Input Delay AVI	0.50	03-15	Analog Input Filter Time (AVI1)	0.01
	0.0 to 10.00 Sec			0.00~20.00 seconds	
04-22	Analog Input Delay ACI1	0.50	03-16	Analog Input Filter Time (ACI)	0.01
	0.0 to 10.00 Sec			0.00~20.00 seconds	
04-23	Analog Input Delay ACI2	0.50	03-17	Analog Input Filter Time (AVI2)	0.01
	0.0 to 10.00 seconds			0.00~20.00seconds	
04-24	Summation of External Frequency Sources	00	03-18	Addition Function of the Analog Input	0
	00:No funtions			0 : Disable addition ( AVI1, ACI, AVI2 )	
	01:AVI+ACI1			1: Enable addition	
	02:ACI1+ACI2				
	03:ACI2+AVI				
	04:Communication master frequency +AVI				
	05:Communication master frequency +ACI1				
	06:Communication master frequency +ACI2				
	07: First frequency + Second Frequency				
08: First frequency - Second Frequency					

VFD-F-Group04-Input Function Parameters			CP2000-Corresponding Parameters		
Parameter	Function	Default	Parameter	Function	Default
	Setting			Setting	
04-25	Summation of First External Frequency Source	00	<b>N/A</b>		
	Settings: 00 : Digital Keypad 01 : AVI External Terminal AVI 02 : External Terminal ACI1 03 : External Terminal ACI2 04 : RS-485 communication interface				
04-26	Summation of Second External Frequency Source	00	<b>N/A</b>		
	Settings: 00 : Digital Keypad 01 : External Terminal AVI 02 : External Terminal ACI1 03 : External Terminal ACI2 04 : RS-485 communication interface				



## ◆ VFD-F-Group05-Multi-step Speed Frequency Parameters vs CP2000-Corresponding Parameters

VFD-F-Group05-Multi-step Speed Frequency Parameters			CP2000-Corresponding Parameters		
Parameter	Function	Default	Parameter	Function	Default
	Setting			Setting	
05-00	1st Step Speed Frequency	0.00	04-00	1st Step Speed Frequency	0
	0.00 ~ 120.00 Hz			0.00~600.00Hz	
05-01	2st Step Speed Frequency	0.00	04-01	2nd Step Speed Frequency	0
	0.00 ~ 120.00 Hz			0.00~600.00Hz	
05-02	3rd Step Speed Frequency	0.00	04-02	3rd Step Speed Frequency	0
	0.00 ~ 120.00 Hz			0.00~600.00Hz	
05-03	4th Step Speed Frequency	0.00	04-03	4th Step Speed Frequency	0
	0.00 ~ 120.00 Hz			0.00~600.00Hz	
05-04	5th Step Speed Frequency	0.00	04-04	5th Step Speed Frequency	0
	0.00 ~ 120.00 Hz			0.00~600.00Hz	
05-05	6th Step Speed Frequency	0.00	04-05	6th Step Speed Frequency	0
	0.00 ~ 120.00 Hz			0.00~600.00Hz	
05-06	7th Step Speed Frequency	0.00	04-06	7th Step Speed Frequency	0
	0.00 ~ 120.00 Hz			0.00~600.00Hz	
05-07	8th Step Speed Frequency	0.00	04-07	8th Step Speed Frequency	0
	0.00 ~ 120.00 Hz			0.00~600.00Hz	
05-08	9th Step Speed Frequency	0.00	04-08	9th Step Speed Frequency	0
	0.00 ~ 120.00 Hz			0.00~600.00Hz	
05-09	10th Step Speed Frequency	0.00	04-09	10th Step Speed Frequency	0
	0.00 ~ 120.00 Hz			0.00~600.00Hz	
05-10	11th Step Speed Frequency	0.00	04-10	11th Step Speed Frequency	0
	0.00 ~ 120.00 Hz			0.00~600.00Hz	
05-11	12th Step Speed Frequency	0.00	04-11	12th Step Speed Frequency	0
	0.00 ~ 120.00 Hz			0.00~600.00Hz	
05-12	13th Step Speed Frequency	0.00	04-12	13th Step Speed Frequency	0
	0.00 ~ 120.00 Hz			0.00~600.00Hz	
05-13	14th Step Speed Frequency	0.00	04-13	14th Step Speed Frequency	0
	0.00 ~ 120.00 Hz			0.00~600.00Hz	
05-14	15th Step Speed Frequency	0.00	04-14	15th Step Speed Frequency	0
	0.00 ~ 120.00 Hz			0.00~600.00Hz	

VFD-F-Group05-Multi-step Speed Frequency Parameters			CP2000-Corresponding Parameters		
Parameter	Function	Default	Parameter	Function	Default
	Setting			Setting	
05-15	PLC Mode	00	N/A		
	00:Disable PLC operation 01:Execute one proram cycle then stop 02:Continuously execute program cycles 03:Execute one program cycle then stop (STOP in between) 04:Continuously execute program cycles(STOP in between)				
05-16	PLC Forward/Reverse Motion	00	N/A		
	00 ~ 32767(0:Forward 1:Reverse)				
05-17	PLC Duration of 1st Step Speed	00			
	00 ~ 65500 Sec				
05-18	PLC Duration of 2nd Step Speed	00			
	00 ~ 65500 Sec				
05-19	PLC Duration of 3rd Step Speed	00			
	00 ~ 65500 Sec				
05-20	PLC Duration of 4th Step Speed	00			
	00 ~ 65500 Sec				
05-21	PLC Duration of 5th Step Speed	00			
	00 ~ 65500 Sec				
05-22	PLC Duration of 6th Step Speed	00			
	00 ~ 65500 Sec				
05-23	PLC Duration of 7th Step Speed	00			
	00 ~ 65500 Sec				
05-24	PLC Duration of 8th Step Speed	00			
	00 ~ 65500 Sec				
05-25	PLC Duration of 9th Step Speed	00			
	00 ~ 65500 Sec				
05-26	PLC Duration of 10the Step Speed	00			
	00 ~ 65500 Sec				
05-27	PLC Duration of 11th Step Speed	00			
	00 ~ 65500 Sec				
05-28	PLC Duration of 12th Step Speed	00			
	00 ~ 65500 Sec				

VFD-F-Group05-Multi-step Speed Frequency Parameters			CP2000-Corresponding Parameters		
Parameter	Function	Default	Parameter	Function	Default
	Setting			Setting	
05-29	PLC	00	<b>N/A</b>		
	00 ~ 65500 Sec				
05-30	PLC Duration of 14th Step Speed	00			
	00 ~ 65500 Sec				
05-31	PLC Duration of 15th Step Speed	00			
	00 ~ 65500 Sec				
05-32	Time Unit Settings	00			
	00: 1 Sec				
	01:0.1Sec				

## ◆VFD-F-Group06-Multi-step Speed Frequency Parameters vs CP2000-Corresponding Parameters

VFD-F-Group06-Multi-step Speed Frequency Parameters			CP2000-Corresponding Parameters		
Parameter	Function	Default	Parameter	Function	Default
	Setting			Setting	
06-00	Over-voltage Stall Prevention	390 780	06-01	Over-voltage Stall Prevention	380.0 760.0
	330 / 660V ~ 410 / 820VDC 00:Disable			230V : 350.0~450.0Vdc 460V : 700.0~900.0Vdc	
06-01	Over-current Stall Prevention during Acceleration	120	06-03	Over-current Stall Prevention during Acceleration	Normal duty: 120%; Light duty: 120%
	20 ~ 150% 00:Disable			Normal duty:0~160% ( 100%: drive's rated current ) Light duty : 0~130% ( 100%: drive's rated current )	
06-02	Over-current Stall Prevention during operation	120	06-04	Over-current Stall Prevention during Operation	Normal duty: 120%; Light duty: 120%
	20 ~ 150% 00: Disable			Normal duty:0~160% ( 100%: drive's rated current ) Light duty : 0~130% ( 100%: drive's rated current )	
06-03	Over-torque Detection Selection	0	06-06	Over-torque Detection Selection (OT1)	0
	00: Over-torque detection disabled. 01: Over-torque detection enabled during constant speed operation (OL2), and operation continues. 03: Over-torque detection enabled during operation (OL2), and operation continues. 04: Over-torque detection enabled during constant speed operation (OL2), and operation halted.			0 : Disable 1: Over-torque detection during constant speed operation, continue to operate after detection. 2: Over-torque detection during constant speed operation, stop operation after detection 3: Over-torque detection during operation, continue to operate after detection 4: Over-torque detection during operation, stop operation after detection	
06-04	Over-torque Detection Level	110	06-07	Over-torque Detection Level (OT1)	120
	30 ~ 150%			10~200% ( 100%: drives rated current )	
06-05	Over-torque Detection Time	0.1	06-08	Over-torque Detection Time (OT1)	0.1
	0.1 ~ 60.0 Sec			0.0~60.0 sec	
06-06	Electronic Thermal Relay Selection	2	06-13	Electronic Thermal Relay Selection (Motor 1)	2
	0~2			0: Motor with constant torque output 1: Motor with variable torque output 2: Electronic Thermal Relay disabled	

VFD-F-Group06-Multi-step Speed Frequency Parameters			CP2000-Corresponding Parameters		
Parameter	Function	Default	Parameter	Function	Default
	Setting			Setting	
06-07	Electronic Thermal Characteristic	60	06-14	Electronic Thermal Characteristic for Motor 1	60.0
	30 ~ 600 Sec			30.0~600.0 Seconds	
06-08	Low Current Detection Level	0	06-71	Low Current Setting Level	0
	00 ~ 100% (00 disabled)			0~100.0%	
06-09	Low Current Detection Time	10	06-72	Low Current Detection Tim	0
	0.0~ 3600.0 Sec			0~360.00 seconds	
06-10	Low Current Detection Processing Mode	01	06-73	Options when Low Current occurs	0
	00: Warn and Ramp to stop 01: Warn and Coast to stop 02: Warn and keep operating			0 : Disable 1 : Warn and coast to stop 2 : Warn and ramp to stop by 2 <sup>nd</sup> deceleration time 3 : Warn and operation continues	
06-11	Fisrt Fault Record	##	06-17	Fisrt Fault Record	0
06-12	Second Fault Record		06-18	Second Fault Record	0
06-13	Third Fault Record		06-19	Third Fault Record	0
06-14	Fourth Fault Record		06-20	Fourth Fault Record	0
	00 No fault occurred		06-21	Fifth Fault Record	0
	01 Over-current (oc)		06-22	Sixth Fault Record	0
	02 Over-voltage (ov)			0 : No fault record	
	03 Overheat (oH)			1: Over-current during acceleration (ocA)	
	04 Overload (oL)			2: Over-current during deceleration (ocd)	
	05 Electronic thermal relay (oL1)			3: Over-current during constant speed(ocn)	
	06 External fault (EF)			4: Ground fault (GFF)	
	07 AC drive IGBT fault (occ)			5: IGBT short-circuit (occ)	
	08 CPU failure (cF3)			6: Over-current at stop (ocS)	
	09 Hardware protection failure (HPF)			7: Over-voltage during acceleration (ovA)	
	10 Over current during acceleration (ocA)			8: Over-voltage during deceleration (ovd)	
	11 Over current during deceleration (ocd)			9: Over-voltage during constant speed (ovn)	
	12 Over current during steady state operation (ocn)			10: Over-voltage at stop (ovS)	
	13 Ground fault (GFF)			11: Low-voltage during acceleration (LvA)	
	14 Under voltage (Lv)			12: Low-voltage during deceleration (Lvd)	
	15 EEPROM WRITE failure (cF1)			13: Low-voltage during constant speed (Lvn)	
	16 EEPROM READ failure (cF2)			14: Stop mid-low voltage (LvS)	
	17 Base Block (bb)			15: Phase loss protection (PHL)	
	18 Motor over load (oL2)			16: IGBT over-heat (oH1)	

VFD-F-Group06-Multi-step Speed Frequency Parameters			CP2000-Corresponding Parameters		
Parameter	Function	Default	Parameter	Function	Default
	Setting			Setting	
	19 Reserved			17: Capacitance over-heat (oH2) (over 40hp)	
	20 Software/password protection (codE)			18: tH1o (TH1 open: IGBT over-heat protection error)	
	21 External emergency stop (EF1)			19: tH2o (TH2 open: capacitance over-heat protection error)	
	22 Phase-Loss (PHL)			20: Reserved	
	23 Low-current (Lc)			21: Drive over-load (oL) (When current is 150% of the rated current, the drive will be overloaded)	
	24 FbL (Feedback Loss)			22: Electronics thermal relay 1 (EoL1)	
	25 Reserved			23: Electronics thermal relay 2 (EoL2)	
	26 Fan Power Fault (FAnP)			24: Motor overheat (oH3) (PTC)	
	27 Fan 1 Fault (FF1)			25: Reserved	
	28 Fan 2 Fault (FF2)			26: Over-torque 1 (ot1)	
	29 Fan 3 Fault (FF3)			27: Over-torque 2 (ot2)	
	30 Fan 1, 2, 3 Fault (FF123)			28: Under current 1 (uc1)	
	31:FF12(Fan1&2 Fault)			29: Under current 2 (uc2)	
	32:FF13(Fan1&3 Fault)			30: Memory write-in error (cF1)	
	33:FF23(Fan2&3 Fault)			31: Memory read-out error (cF2)	
	34:Fv(gate drive low volt)			32: Reserved	
	35~40: Reserve			33: U-phase current detection error (cd1)	
	41: HPP1 (GFF)			34: V-phase current detection error (cd2)	
	42: HPP2 (CC)			35: W-phase current detection error (cd3)	
	43: HPP3 (OC)			36: Clamp current detection error (Hd0)	
	44: HPP4 (OV)			37: Over-current detection error (Hd1)	
	45: CF3.3 (U current sensor)			38: Over-voltage detection error (Hd2)	
	46: CF3.4 (V current sensor)			39: Ground current detection error (Hd3)	
	47: CF3.5 (W current sensor)			40: Auto tuning error (AuE)	
	48: CF3.6 (DC Bus)			41: PID feedback loss (AFE)	
	49: CF3.7 (Isum)			42~47 Reserved	
	50: CF3.8 (OH)			48: ACI reference input loss (ACE)	
				49: External fault input (EF)	
				50: Emergency stop (EF1)	
				51: External Base Block (BB)	
				52: Password Error (Pcode)	

VFD-F-Group06-Multi-step Speed Frequency Parameters			CP2000-Corresponding Parameters		
Parameter	Function	Default	Parameter	Function	Default
	Setting			Setting	
	N/A			53 : Reserved 54: Communication error (cE1) 55: Communication error (cE2) 56: Communication error (cE3) 57: Communication error (cE4) 58: Communication Time-out (cE10) 59: PU Time-out (cP10) 60: Brake transistor error (bF) 61: Y-connection/ $\Delta$ -connection switch error (ydc) 62: Decel. Energy Backup Error (dEb) 63: Slip error (oSL) 64~65 : Reserved 73: External safety gate S1 74: FIRE mode output 79: U phase over current (Uocc) 80: V phase over current (Vocc) 81: W phase over current (Wocc) 82: U phase output phase loss (OPHL) 83: V phase output phase loss (OPHL) 84: W phase output phase loss (OPHL) 101: CANopen software disconnect1 (CGdE) 102: CAN open software disconnect2 (CHbE) 103: CANopen synchronous error (CSYE) 104: CANopen hardware disconnect (CbFE) 105: CANopen index setting error (CIdE) 106 : CAde CANopen 107 : CFre CANopen	

VFD-F-Group06-Multi-step Speed Frequency Parameters			CP2000-Corresponding Parameters		
Parameter	Function	Default	Parameter	Function	Default
	Setting			Setting	
06-15	Parameter Reset	00	00-02	Parameter Reset	0
	09: Reset parameters (50Hz, 220/380) 10: Reset parameters (60Hz, 220/440)			0: No function 1: Read only 6: Reset PLC (including CANopen Master Index) 7: Reset CANopen Index (Slave) 9: All parameters are reset to factory settings(base frequency is 50Hz) 10: All parameters are reset to factory settings (base frequency is 60Hz)	
06-16	Parameter Protection Password Input	00	00-07	Parameter Protection Password Input	0
	00~65535			0 ~ 65535 0~4 : Recording # of times of entering wrong passwords	
06-17	Parameter Protection Password Setting	00	00-08	Parameter Protection Password Setting	0
	00~65535			0 ~ 65535 0 : No password protection / password is entered correctly (Pr00-07) 1: Parameter is locked	
06-18	Recording Mid/Low Voltage while running the drive.	0	N/A		
	1 : NOT Recording low voltage and reset manually 2 : Recording low voltage and reset manually				



◆ VFD-F-Group07-AC Drive and Motor Parameters vs CP2000-Corresponding Parameters

VFD-F-Group07-AC Drive and Motor Parameters			CP2000-Corresponding Parameters		
Parameter	Function	Default	Parameter	Function	Default
	Setting			Setting	
07-00	Identity Code of AC Drive	Read only	00-00	ID Code of the AC Motor Drive	Read Only
	Display by model type			By model	
	N/A			4: 230V, 1HP (0.75kW)	
			5: 460 V, 1HP (0.75kW)		
			6: 230V, 2HP (1.5kW)		
			7: 460 V, 2HP (1.5kW)		
			8: 230V, 3HP (2.2kW)		
			9: 460 V, 3HP (2.2kW)		
			10: 230V, 5HP (3.7kW)		
			11: 460 V, 5HP (3.7kW)		
			12: 230V, 7.5HP (5.5kW)		
			13: 460 V, 7.5HP (5.5kW)		
			14: 230V, 10HP (7.5kW)		
			15: 460V, 10HP (7.5kW)		
			16: 230V, 15HP (11kW)		
			17: 460V, 15HP (11kW)		
			18: 230V, 20HP (15kW)		
			19: 460V, 20HP (15kW)		
			20: 230V, 25HP (18.5kW)		
			21: 460V, 25HP (18.5kW)		
			22: 230V, 30HP (22kW)		
			23: 460V, 30HP (22kW)		
	24: 230V, 40HP (30kW)				
	25: 460V, 40HP (30kW)				
	26: 230V, 50HP (37kW)				
	27: 460V, 50HP (37kW)				
	28: 230V, 60HP (45kW)				
	29: 460V, 60HP (45kW)				
	30: 230V, 75HP (55kW)				
	31: 460V, 75HP (55kW)				
	32: 230V, 100HP (75kW)				
	33: 460V, 100HP (75kW)				

VFD-F-Group07-AC Drive and Motor Parameters			CP2000-Corresponding Parameters			
Parameter	Function	Default	Parameter	Function	Default	
	Setting			Setting		
	N/A			34: 230V, 125HP(90kW) 35: 460V, 125HP (90kW) 37: 460V, 150HP (110kW) 39: 460V, 175HP(132kW) 41: 460V, 215HP(160kW) 43: 460V, 250HP(185kW) 45: 460V, 300HP(220kW) 47: 460V, 375HP(280kW) 49: 460V, 425HP(315kW) 51: 460V, 475HP(355kW) 53: 460V, 536HP(400kW) 93 : 460V, 5.5HP (4.0kW)		
07-01	Rated Current of AC Drive	Read only	00-01	Display AC Motor Drive Rated Current	Read Only	
	Display by model type			By model		
07-02	Full-load Current of Motor	100%	05-01	Full-Load current of Induction Mortor	0	
	30 ~ 120%			1(Amps) 10~120% of the drive's rated current		
07-03	No-load Current of Motor	30%	05-05	No Load Current of Induction Mpotor	0	
	1 ~ 99%			1(Amps) 0~ Pr.05-01 of factory setting		
07-04	Auto Slip Compensation Gain	0	07-27	Slip Compensation Gain ( V/F and SVC control mode )	0.00	
	0.0~3.0			0.00~10.00		
07-05	Rated Slip Frequency of Motor Factory	0	05-03	Rated Rotational Speed of Induction Motor	1710	
	0.00 ~ 20.00Hz			1 (rpm) 0~65535 1710(60Hz 4 poles) ; 1410(50Hz 4 poles)		
07-06	Auto Torque Compensation Gain	0	07-26	Torque Compensation Gain (V/F control mode )	0	
	0~10			0~10		
07-07	Torque Compensation Gain by Manual Operation	0	N/A			
	0.0~10.0					
07-08	Calculate Total Running Time of the Motor (Min)	0	05-31	Accumulated Motor Functioning Time (minute)	0	
	00 to 1440Min			00~1439		

VFD-F-Group07-AC Drive and Motor Parameters			CP2000-Corresponding Parameters		
Parameter	Function	Default	Parameter	Function	Default
	Setting			Setting	
07-09	Calculate Total Running Time of the Motor (Day)	0	05-32	Accumulated Motor Operation Time (day)	0
	00 to 65535 Day			00~65535	
07-10	Poles of Motor	4	05-04	Pole Number of Induction Motor 1	4
	2~10			2~20	
07-11	Reserved		N/A		

## ◆ VFD-F-Group08-Special Parameters vs CP2000-Corresponding Parameters

VFD-F-Group08-Special Parameters			CP2000-Corresponding Parameters		
Parameter	Function	Default	Parameter	Function	Default
	Setting			Setting	
08-00	DC Brake Current Level	00	07-01	DC Brake Current Level	0
	00~100%			0~100%	
08-01	DC Brake Time during Start-up	0.0	07-02	DC Brake Time at Start-up	0.0
	0.0~60.0Sec			0.0~60.0 seconds	
08-02	DC Brake Time during Stopping	0.0	07-03	DC Brake Time at Stop	0.0
	0.0~60.0Sec			0.0~60.0 seconds	
08-04	Momentary Power Loss Operation Selection	00	07-06	Restart after Momentary Power Down	0
	00: Disable			0: Stop operation	
	01: Trace from top downward 02: Trace from bottom upward			1: Speed search starting from last speed before the moment of power down 2: Speed search starting from minimum output frequency	
08-05	Maximum Allowable Power Loss Time	2.0	07-07	Allowable Time for Power Down	2.0
	0.1~20.0Sec			0.1~20.0 seconds	
08-06	Speed Search Time	0.5	07-08	Base Block Time	0.5
	0.1~5.0Sec			0.1~5.0 seconds	
08-07	Maximum Current for Speed Searching	110	07-09	Maximum Current for Speed Searching	100
	30~150%			20~200%	
08-08	BB Speed Search Method	00	07-10	Base Block Speed Search (oc, ov, bb)	0
	00: Trace from top downward			0: Stop operation	
	01: Trace from bottom upward			1: Speed search starting from last speed before the moment of base block 2: Speed search starting from minimum output frequency	
08-09	Auto Restart Times After Fault	00	07-11	# of Auto Reset after Errors Occurred	0
	00~10			0~10	
08-10	Auto Restart Time after Fault	600	07-33	Recovery Time to Pr.07-11(# of auto reset after error occurred)	60.0
	00 to 60000 sec			00~60000seconds	
08-11	Operation Frequency Inhibition 1 UP	0.00	01-28	Upper limit of Frequency 1 setting not allowed	0.00
	0.00 ~ 120.00 Hz			0.00~600.00Hz	
08-12	Operation Frequency Inhibition 1 DOWN	0.00	01-29	Lower limit of Frequency 1 setting not allowed	0.00
	0.0 ~ 120.00 Hz			0.00~600.00Hz	
	0~1000			0~10000	

VFD-F-Group08-Special Parameters			CP2000-Corresponding Parameters		
Parameter	Function	Default	Parameter	Function	Default
	Setting			Setting	
08-13	Operation Frequency Inhibition 2 UP	0.00	01-30	Upper limit of Frequency 2 setting not allowed	0.00
	0.00 ~ 120.00 Hz			0.00~600.00Hz	
08-14	Operation Frequency Inhibition 2 DOWN	0.00	01-31	Lower limit of Frequency 2 settubg not allowed	0.00
	0.00 ~ 120.00 Hz			0.00~600.00Hz	
08-15	Operation Frequency Inhibition 3 UP	0.00	01-32	Upper limit of Frequency 3	0.00
	0.00~120.00Hz			0.00~600.00Hz	
08-16	Operation Frequency Inhibition 3 DOWN	0.00	01-33	Lower limit of Frequency 3	0.00
	0.00~120.00Hz			0.00~600.00Hz	
08-17	Automatic Energy-saving	00	07-21	Auto Energy-saving Operation	0
	00 :Disable 01:Enable			0: Disable; 1: Enable	
08-18	Automatic Voltage Regulation (AVR)	00	07-23	Auto Voltage Regulation(AVR) Function	0
	00: AVR Enabled			0: Enable AVR	
	01: AVR Disabvled			1: Disable AVR	
	02: AVR disabled during deceleration			2: Disable AVR during deceleration	
08-19	Software Setting	380	07-00	Setup Software Brake Level	380
	of the Brake Level	760		of the Brake Level	760
	370 / 740V~410 / 820VDC 00:Disable			230Vseries: 350.0~450.0Vdc 460V series: 700.0~900.0Vdc	
08-20	Vibration Compensation Factor	0	07-32	Motor Hunting Gain	1000
	0~1000			0~10000	

### ◆ VFD-F-Group09-Communication Parameters & CP2000-Corresponding Parameters

VFD-F-Group09-Communication Parameters			CP2000-Corresponding Parameters		
Parameter	Function	Default	Parameter	Function	Default
	Setting			Setting	
09-00	Communication Address	01	09-00	COM1 Communication Address	1
	01 ~ 254			1~254	
09-01	Transmission Speed (Baud Rate)	01	09-01	COM1 Transmission Speed	9.6
	00: Baud rate 4800			4.8 ~ 115.2Kbps	
	01: Baud rate 9600				
	02: Baud rate 19200				
	03: Baud rate 38400				
09-02	Transmission Fault Processing	03	09-02	COM1 Transmission Fault Process	3
	00: Warn and keep operating			0: Warn and continue operation	
	01: Warn and RAMP to stop			1: Warn and ramp to stop	
	02: Warn and COAST to stop			2: Warn and coast to stop	
	03: No warning and no display			3: No warning and continue operation	
09-03	Time-out Detection during Transmission	0.0	09-03	Time-out Detection during Transmission (COM1)	0.0
	0.0~60.0 sec			0.0 ~ 100.0 seconds	
	0.0: Disable				
09-04	Communication Mode	00	09-04	COM1 Communication Protocol	1
	00: 7-bit for ASCII			0: 7N1 (ASCII)	
	01: 8-bit for ASCII			1: 7N2 (ASCII)	
	02: 8-bit for RTU			2: 7E1 (ASCII)	
09-05	Parity Check and stop bit	00	09-05	3: 7O1 (ASCII)	
	00: None parity + 2 stop bit			4: 7E2 (ASCII)	
	01: Even parity + 2 stop bit			5: 7O2 (ASCII)	
	02: Odd parity + 2 stop bit			6: 8N1 (ASCII)	
	03: None parity + 1 stop bit			7: 8N2 (ASCII)	
	04: Even parity + 1 stop bit			8: 8E1 (ASCII)	
	05: Odd parity + 1 stop bit			9: 8O1 (ASCII)	
		10: 8E2 (ASCII)			
		11: 8O2 (ASCII)			
		12: 8N1 (RTU)			
		13: 8N2 (RTU)			
		14: 8E1 (RTU)			
		15: 8O1 (RTU)			
		16: 8E2 (RTU)			
		17: 8O2 (RTU)			

VFD-F-Group09-Communication Parameters			CP2000-Corresponding Parameters		
Parameter	Function	Default	Parameter	Function	Default
	Setting			Setting	
09-06	Communication Operation Command 1	0		Communication function 2000H	
	Bit0~1			Bit0~3	
	00B=Disable			0 : Disable	
	01B=Stop			1 : Stop	
	10B=Enable			2 : Enable	
	11B=JOG enabled				
	Bit2~3 Reserved				
	Bit4~5			Bit4~5	
	00B:Disable			00B: Diable	
	01B:FWD command			01B: FWD command	
	10B:REV command			10B: REV comand	
	11B:Direction change command			11B: Direction change command	
	Bit 6~7			Bit6~7	
	00B:1st acce/decel speed			00B : 1st accel/decel speed	
	01B:2nd acce/decel speed			01B : 2nd accel/decel speed	
	10B:3rd acce/decel speed			10B : 3rd accel/decel speed	
	11B:4th acce/decel speed			11B : 4th accel/decel speed	
	Bit8~11			Bit08~11	
	0000B:Master speed			0000B: Master speed	
	0001B:1st speed			0001B: 1st speed	
	0010B:2nd speed			0010B: 2nd speed	
	0011B:3rd speed			0011B: 3rd speed	
	0100B:4th speed			0100B: 4th speed	
	0101B:5th speed			0101B: 5th speed	
	0110B:6th speed			0110B: 6th speed	
	0111B:7th speed			0111B: 7th speed	
	1000B:8th speed			1000B: 8th speed	
	1001B:9th speed			1001B: 9th speed	
	1010B:10th speed			1010B: 10th speed	
	1011B:11th speed			1011B: 11th speed	
				1100B: 12th speed	
				1101B: 13th speed	
				1110B: 14th speed	
				1111B: 15th speed	

VFD-F-Group09-Communication Parameters			CP2000-Corresponding Parameters		
Parameter	Function	Default	Parameter	Function	Default
	Setting			Setting	
	Bit12: Select Bit6~11 function  Bit13~15 Reserved			Bit12 1 : Eabke bit06-11  Bit13~14 00B: Disable 01B: Operation comand from digital keypad 10B: Operation command from parameter setting ( Pr00-21 ) 11B: Modify source of the operation command  Bit15 Reserved	
09-07	Communication Frequency Setting	60.00	09-10	Communication Frequency	60.00
	0~120.00Hz			0.00~600.00Hz	
09-08	Communication Operation Command 2	0		Communication Operation Function 2002H	
	Bit0: 1: EF ON Bit1: 1: Reset Bit2: 0: BB OFF, 1: BB ON Bit3~15: Reserved			Bit0 1 : E.F. ON Bit1 1 : Reset Bit2 1 : Base Block ( B.B ) ON Bit3~5 Reserved	
09-09	Modbus /BACnet Switch	0	09-31	COM1 Protocol	0
	0: Modbus 1: BACnet Master 2: BACnet Slaver			0: RS485 1: BACnet	
09-10	BACnet DNET	1	09-50	BACnet Dnet	1
	1~65535			0~127	
09-11	Device Instance	0	09-52	BACnet Device ID L	1
	0~65535			0~9999	
			09-53	BACnet Device ID H	0
				0~63	
09-12	DCC password	0	09-56	BACnet Passoword	0
	0~65535			0~65535	



### ◆ VFD-F-Group10-PID Control Parameters vs CP2000-Corresponding Parameters

VFD-F-Group10-PID Control Parameters			CP2000-Corresponding Parameters		
Parameter	Function	Default	Parameter	Function	Default
	Setting			Setting	
10-00	Input Terminal for PID Feedback	00	03-00	Analog Input 1 (AVI1)	1
	00: Disable 01: Input via AVI 02: Input via ACI1 03: Input via ACI2 04: Input via External Reference		03-01	Analog Input 2(ACI)	
			03-02	Analog Input 3 (AVI2)	
				0: Disable 1: Frequency command (torque limit under torque control mode) 4: PID target value 5: PID feedback signal 6: PTC thermistor input value 11: PT100 thermistor input value 12~17: Reserve	
10-01	PID Control Detection Signal Reference	1000.0	00-25	User Defined Property	0
	1.0~6550.0			Bit 0~3: user defined on decimal places 0000b: no decimal place 0001b: one decimal place 0010b: two decimal place 0011b: three decimal place Bit 4~15: user define on unit 000xh: Hz 001xh: rpm 002xh: % 003xh:kg	
			00-26	User Define Max. Value	0
				0 : Disable 0000b: 0~65535 (No decimal place in Pr.00-25 setting) 0001b: 0.0~6553.5 (One decimal place in Pr.00-25 setting) 0010b: 0.0~655.35(Two decimal place in Pr.00-25 setting) 0011b: 0.0~65.536 (Three decimal place in Pr.00-25 setting)	
			00-27	User Defined Value	Read Only
				Read Only	
10-02	PID Normal/Inverse Control	0	08-00	Input Terminal for PID feedback	0
	00:Normal (Err=SP-FB) 01:Inverse (Err=FB-SP)			0: Disable 1: Negative PID feedback: input from external terminal AVI (Pr03-00) 4: Positive PID feedback from external terminal AVI (Pr03-00)	

VFD-F-Group10-PID Control Parameters			CP2000-Corresponding Parameters		
Parameter	Function	Default	Parameter	Function	Default
	Setting			Setting	
10-03	Proportional Gain (P)	1.0	08-01	Proportional Gain (P) 0.0	1.0
	0.0~10.0			0.0~500.0	
10-04	Integral Time (I)	1.00	08-02	Integral Time (I)	1.00
	0.00 ~ 100.00 Sec			0.00~100.00 seconds	
10-05	Differential Time (D)	0.00	08-03	Derivative Time (D)	0.00
	0.00~1.00Sec			0.00~1.00 seconds	
10-06	Upper Bound for Integral Control	100	08-04	Upper Limit of Integral Control	100.0
	00~200%			0.00~100.0%	
10-07	Primary Low Pass Filter Time	0.0	08-07	PID Delay Time	0.0
	0.0 ~ 2.50 Sec			0.0~35.0 seconds	
10-08	PID Feedback Signal Range	600.0	08-13	PID Deviation Level	10.0
	0.0~10-01			1.0 ~ 50.0%	
10-09	Unusual Feedback signal of deviation	0.0	08-14	PID Deviation Time	5.0
	0.0: Disable 0.0 ~ 3600.0 Sec			0.1~300.0seconds	
10-10	PID Feedback Signal Fault Processing Mode	01	08-09	Action on Feedback Error	0
	00:Warn and RAMP stop 01:Warn and COAST stop 02:Warn and keep operating			0: Warn and keep operation 1: Warn and ramp to stop 2: Warn and coast to stop 3: Warn and operate at last frequency	
10-11	PID Minimum Output Frequency	0	01-34	Zero-speed Mode	0
	0: By PID controller 1:By VFD, but if the lower bound frequency is zero, then it is set up in accordance with lowest frequency, otherwise it goes with lower bound frequency			0: Output waiting 1: Zero-speed operation 2: Output at Minimum Frequency (the 4th output frequency)	
10-12	PID Mode Selection	0	<b>N/A</b>		
	0: Manual PID 1: Auto-Tuning PID				

## ◆ VFD-F-Group11-Fan and Pump Control Parameters vs CP2000-Corresponding Parameters

VFD-F-Group11-Fan and Pump Control Parameters			CP2000-Corresponding Parameters		
Parameter	Function	Default	Parameter	Function	Default
	Setting			Setting	
11-00	V/f Curve Selection	00	01-43	V/f Curve Selection	0
	00: Determined by group 1 01: 1.5 power curve 02: 1.7 power curve 03: 2 power curve 04: cube curve			0: normal V/F curve 1: Curve to the power of 1.5 2: Curve to the power of 2	
11-01	Circulative Control	00	12-00	Circulative Control	0
	00: Disable 01: Fixed time circulation (by time, maximum 8 pumps) 02: Fixed amount circulation (by PID) (maximum 4 sets) 03: Fixed amount control (1 VFD runs with 8 pumps) 04: Fixed amount circulation + Fixed time circulation(max 4sets) 05: Fixed amount control+fixed time circulation(1 VFD runs with 8 pumps)			0: Disable 1: Fixed Time Circulation (by time) 2: Fixed amount circulation (by PID) 3: Fixed amount control 4: Fixed Time Circulation+ Fixed amount circulation 5: Fixed Time Circulation+ Fixed amount control	
11-02	02 Multiple Motors Control	01	12-01	Number of motors to be connected	1
	01~08			1 to 8	
11-03	Fixed Time Circulation Setting	00	12-02	Operating time of each motor (minute)	0
	00 ~ 65500 Min			0 to 65500 min	
11-04	Motor Switch Delay Time	1.0	12-03	Delay Time due to the Acceleration (or the Increment ) at Motor Switching	10
	0.0 ~ 3600.0 sec			0.0 to 3600.0 sec	
11-05	Motor Switch Delay Time during Fixed Amount Circulation	10.0	12-05	Delay time while fixed amount circulation at Motor Switching (second)	100
	Auxiliary starts/stops delay time 0.0 to 3600.0 sec			0.0 to 3600.0 sec	
11-06	Motor Switch Frequency during Fixed Amount Circulation	60.00	12-06	Frequency when switching motors at fixed amount circulation (Hz)	6000
	Auxiliary starting frequency 0.00 to 120.00 Hz			0.00 to 600.00 Hz	
11-07	Sleep Mode Timer	0.00	08-12	Sleep Time	0.0
	0.00 : OFF 0.00 to 3600.0sec			0.0 ~ 6000.0 seconds	

VFD-F-Group11-Fan and Pump Control Parameters			CP2000-Corresponding Parameters		
Parameter	Function	Default	Parameter	Function	Default
	Setting			Setting	
11-08	Sleep Frequency of Sleep Process (hz) / Wake Up Feedback%	0.00	08-10	Sleep Frequency	0.00
	Frequency of Sleep Process (%) 0.00 to 11-09 ( Hz or %)			0.00 ~ 600.00Hz or 0~200.00%	
11-09	Wake Up Frequency of Sleep Process	0.00	08-11	Wakeup Frequency	0.00
	0.00 to 120.0 (Hz or %)			0.00 ~ 600.00Hz or 0~200.00%	
11-10	Process of Fixing Malfunction while Fixed Amount Circulation	0	11-11	Stop Frequency of Auxiliary Motor	0.00
	0: Turn off all output. 1: Motors power by line (line power) continue to run.			0.00 to 120.0Hz	
11-11	Stop Frequency of Auxiliary Motor	0.00	12-08	Frequency when stopping auxiliary motor (Hz)	0
	0.00 to 120.0Hz			0.00 to 600.00 Hz	
11-12	Setting of Sleep Mode Function(only PID)	0	08-18	Setting of Sleep Mode Function(only PID)	0
	0:Refer to PID Output Command 1:Refer to PID Feedback signal			0:Refer to PID Output Command 1:Refer to PID Feedback signal	
11-13	Integral upper limit of the wake-up point	50	08-05	PID Output Frequency Limit	100.0
	0~200%			0.0~110.0%	
11-14	Delay Time when Switching Motors (2)	1.0	12-04	Delay time due to the deceleration (or the decrement ) at Motor Switching(sec)	10
	0.0 ~ 3600.0 sec			0.0 to 3600.0 sec	
11-15	Fire Mode Function	0	06-80	Fire mode	0
	0: Disable 1: Running forward(Open loop) 2: Running backward (Open loop)			0: Disable 1: Forward operation 2: Reverse Operation	
11-16	Operating Frequency at Fire Mode	60.00	06-81	Operating Frequency when running Fire Mode	60.00
	0.0~Fmax			0.00 to 600.00Hz	
11-17	Number of times to Reactivate while Unusual Fire Mode	0	06-84	Reset auto-counter of the Fire Mode	0
	0~10 (times)			0~10	
11-18	Bypass Function	0	06-82	Bypass Fire Mode enabled	0
	0: Disable 1: Enable			0: Disable Bypass 1: Enable Bypass	
11-19	Bypass Delay time while Fire Mode	0.0	06-83	Delayed Time when Bypass Fire Mode	0
	0.0~6550.0 sec			0.0 to 6550.0 sec	



Transmisiones Ltda. Carrera 68 B # 21 A -  
24, bodega UE 28- 1 Parque Industrial  
Montevideo PBX: (57+1) 4126898  
Bogotá - Colombia  
info@transmisiones.de  
www.transmisiones.de